



Virginia Commonwealth University
VCU Scholars Compass

Theses and Dissertations

Graduate School

2010

Adsorption studies by pulsed streaming potentials in microfluidic channels

ThuTrang Nguyen
Virginia Commonwealth University

Follow this and additional works at: <https://scholarscompass.vcu.edu/etd>

 Part of the [Chemistry Commons](#)

© The Author

Downloaded from

<https://scholarscompass.vcu.edu/etd/2217>

This Thesis is brought to you for free and open access by the Graduate School at VCU Scholars Compass. It has been accepted for inclusion in Theses and Dissertations by an authorized administrator of VCU Scholars Compass. For more information, please contact libcompass@vcu.edu.

Abstract

Adsorption studies by pulsed streaming potentials in microfluidic channels.

By ThuTrang T. Nguyen

A thesis submitted in partial fulfillment of the requirements for the degree of Master of Science at Virginia Commonwealth University.

Virginia Commonwealth University, 2010

Director: Dr. Julio C. Alvarez
Associate Professor of chemistry

In this work, an instrument for measuring pulsed streaming potentials was constructed and optimized for analytical and teaching applications. This thesis is divided in three chapters, the first one deals with the construction of the instrument, the second describes a microfluidic experiment designed for undergraduate and high school students using this instrument, and the third one shows an application of pulsed streaming potential measurements in the detection of heparin. Streaming potential is the electric field generated when a liquid is forced to flow by a pressure gradient through a channel or other stationary charged surfaces.^{1,2} These measurements were done in microfluidic channels built with commodity plastics such polycarbonate (PC) and cyclic olefin copolymer (COC). Microfluidics studies the changing behaviors of fluids within small volumes, (nL, pL, fL), or small sizes, (channel size is about 100 nanometers to several hundred micrometers).³ With low level of complexity in instrumentation, low cost, and easy way to implement, the system is ideally suited as a teaching instrument in high

school and undergraduate labs. By creating simple experiments with suitable processing time, our goal is to introduce to students several fundamental concepts related to ionic solutions, electrochemical potentials, and charged surfaces. By doing the experiments, students can improve their analytical skills, and problem solving skills. They can learn many useful techniques, such as measuring pH, measuring conductivity, and calculating zeta potential. For these experiments, Polycarbonate (PC) is chosen as microfluidic platform because it is commercially available and the cost is low enough for a school budget. PC microfluidic channels are modified by different charged species, which are the anionic poly (sodium 4-styrenesulfonate) (PSS), the cationic poly(allylamine) hydrochloride (PAH), and bovine serum albumin (BSA). Since the relative polarity of streaming potential is determined by the surface charge, the signal detected is the reverse of streaming potential with different charged modified surfaces. With the same strategy, heparin is detected by real time monitoring adsorption on COC and PC microfluidic channels modified by protamine. The results on the two kinds of channels are compared. For COC channels, linear correlation of initial adsorption rates is found in the range between 0.00074 units/ml and 0.050 units/ml. For PC channels it is between 0.00074 units/mL and 0.074 units/mL. Streaming potential measurements have been useful for determining the charge of such surfaces as capillaries,¹ membranes,⁴ and other porous materials.⁵ There has been no work done using pulsed streaming potential measurements for sensing purposes in microfluidic channels. With our sensing device, no referent electrode is needed since the signal acquisition is made using pulsed flow, so drifting of the measure voltages can be avoided. In addition, no such fluorescent, electrochemical, or radioactive labeling is required for detection.

CHAPTER 1:

Construction of streaming potential device

1.1- Introduction:

In this chapter, the process to build a device for measuring streaming potentials in plastic microfluidic channels is described. Streaming potentials are one of several electrokinetic effects, which along with electrophoresis,⁶ electroosmosis,^{7, 8} streaming potential, and sedimentation potentials are influenced by the Zeta potential of the surface as observed for colloidal particles.⁶ In a colloid system of solid and liquid, at the interface of the particle and the surrounding liquid environment, an electric double layer is formed by the surface charge of the particle and counter ions in solution. The liquid layer surrounding the particle exists as two parts. The first one is the Stern layer, where the ions are kept strongly by the surface charge. The second part is the diffuse region, where the ions are less strongly bound to the surface. When the particle moves, the ions inside the Stern layer and the ions on the closest part of the diffuse layer of the particle surface move with the particle. The rest of the diffuse layer stays with the bulk liquid. The plane that separates the moving and the sessile layer of ions part is called the plane of shear. The potential at this plane is called Zeta potential.^{6, 9, 10} (Figure 1.1)

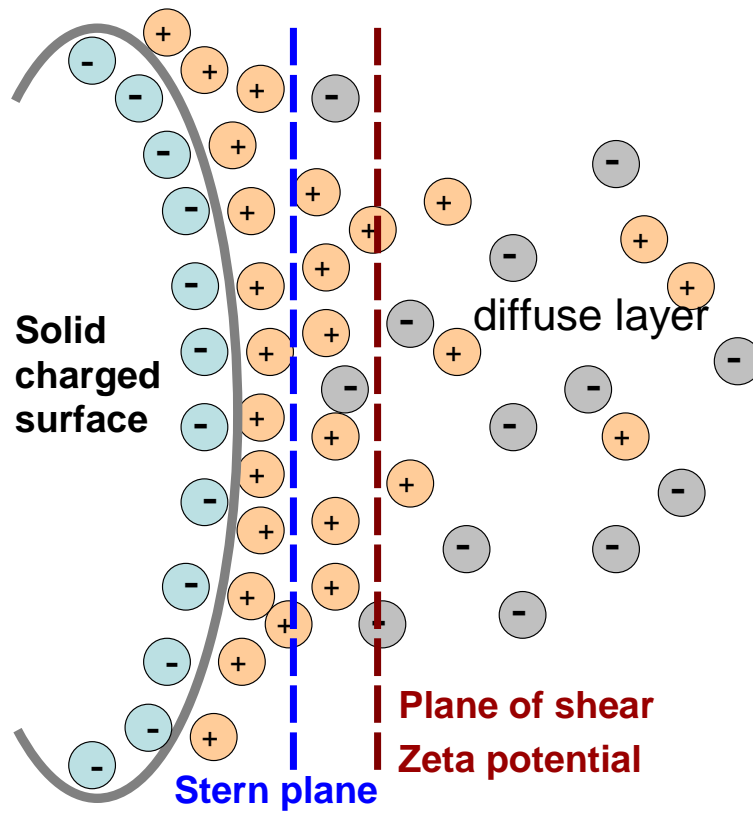

Figure 1.1: Zeta potential in colloid systems.

In colloid science, measurement of the Zeta potential has played an important role in accessing the stability of colloidal systems. Zeta potential of surfaces can be determined by measuring electroosmotic mobility,^{11,12,13,14} which implies measuring the response of a small spherical particle in an applied electrical field. Another method consists in measuring streaming current or streaming potential generated when pressure driven flow of liquid passes through a channel.^{15,16,17} Similar to what happens in colloidal particles, inside a microchannel, at the interface of the channel wall surface and liquid, an electric double layer (EDL) is generated by the surface charge of the wall and the counter ions in the solution. This EDL is about 1 nm thick, which changes according to the ionic strength of the solution. When hydrostatic pressure is applied to the solution in the channel, liquid is forced to move forward inside the channel. This movement causes a displacement of the mobile counter ions at the EDL, which in turn produces an excess of counter ions at the downstream end of the channel while the upstream end lacks of counter ions. The result is a streaming potential (ΔE) that is generated between the two ends of the channel.^{6, 18} (Figure 1.2)

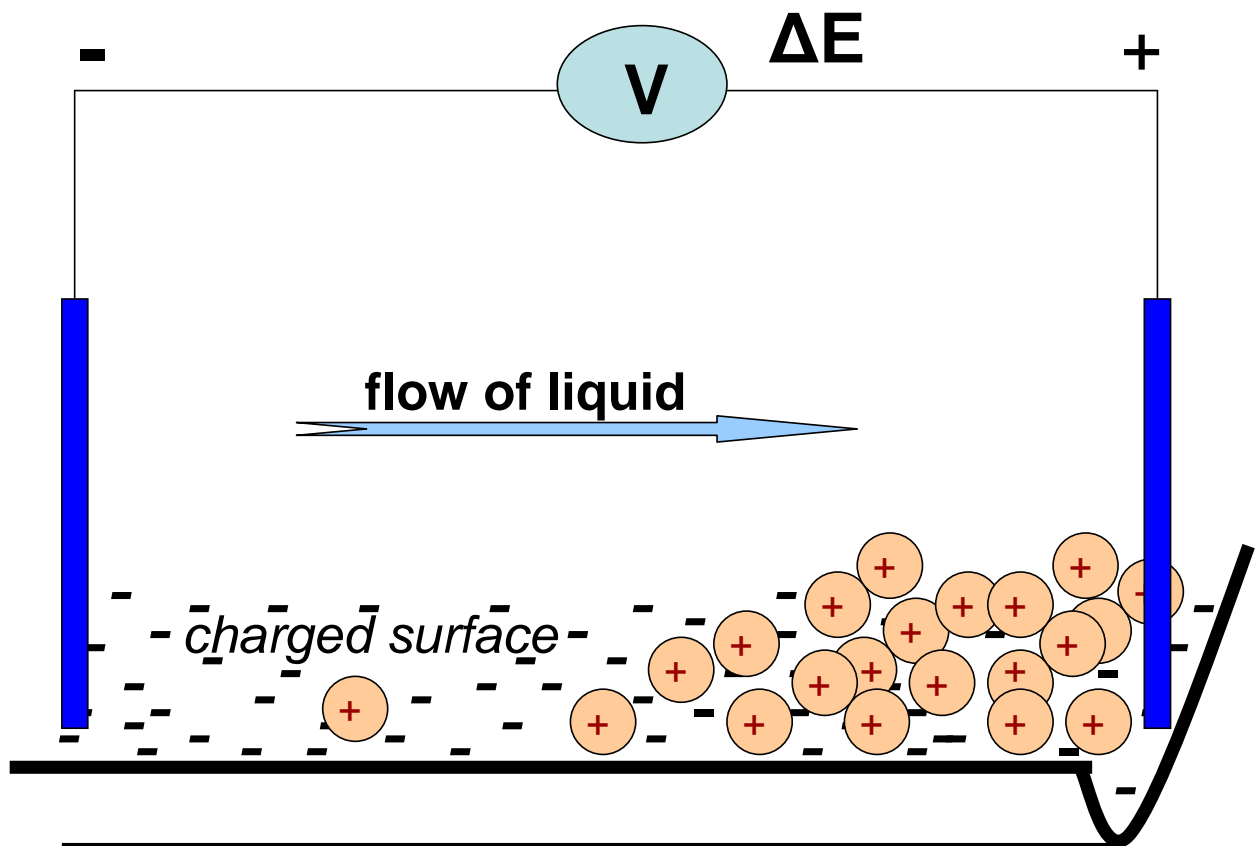

Figure 1.2: Electric double layer, (EDL), in a microfluidic channel under flow condition.

In microfluidics, streaming potential measurements are usually employed to determine the Zeta potential of microchannels.¹⁹ R.A Van Wagenen and J.D. Andrade (1980), as well as Z. Adamczyk and coworkers (2004) measured streaming potentials in the parallel- plate channel setup using reference electrodes.^{20, 21} However, reference electrodes always need special solutions to maintain their electrochemical potential. The instrument to measure streaming potential described in this work can operate in microfluidic channels with non-reference electrodes and it was designed to work with pressure- driven flow under pulsed conditions. The instrument is low cost and may be adaptable for traveling kits.

1.2- Construction:

1.2.1- Construction of the components:

1.2.1a- Construction of the valve control circuit and the voltage follower circuit:

Materials: For the valve control circuit, 1k ohm resistor (part number 1.0 KH- ND), transistor NPN 30V (part number 497- 3106- 5- ND), rectangular Header Male Pin (number part 929647- 02- 36- ND), rectifier 1 A 200V DO- 41 (part number 1N4003- TPMSCT- ND), connector terminal female 18- 24AWG (part number WM1008 –ND), and prototype bread boards were purchased through Digi- Key (Thief River Fall, MN). Cable for connection between components, alligators clips, rosin core solder, and light emitting diodes (LEDs), green and yellow, were purchased from local stores. For the voltage follower circuit, ceramic capacitor 0.1 μ F(part number 445-2634-ND), capacitor 3.3 μ F 63V (part number 565-2262-1-ND), JFET operational amplifier 8DIP linear (part number 296-1780-5-ND), 8 pin solder tail dip socket (part number A-400-ND) and resistor 470 ohms $\frac{1}{4}$ W 5% tolerance (part number 470QBK-ND) were purchased from

Digi- Key (Thief River Falls, MN). Alligators and cable were purchased from a local RadioShack store.

To construct the circuits, prototype breadboards were used. The electronic components were placed as in the component placement guides illustrated in Figure 1.3 and Figure 1.5. The terminals of the electric components were soldered on the back side of the breadboards by using conventional rosin core solder and a soldering iron. For the valve control circuit, the terminals of the components were soldered following the terminal component guide 1 (Figure 1.4). Terminal 1 was connected to terminal 3; Terminal 2 to terminal 7; Terminal 9 to terminal 7. The terminals 8, 15, 16, and 19 were connected together. Terminal 20 was connected to terminal 21. The terminals 17, 18, 22, 33, 25, 26 and 30 were connected together. Terminal 4 was connected to terminal 6; Terminal 5 to terminal 12. The terminals 14, 11, 31 and 32 were connected together. The terminals 13, 23, 24, and 27 were connected together. Terminal 28 was connected to terminal 29. For the voltage follower circuit, terminal component guide 2 (Figure 1.6) was used. The terminals 1, 2, and 10 were connected together. The terminals 9, 17 and 18 were connected together. Terminal 3 was connected to terminal 4; Terminal 5 to terminal 6; Terminal 7 to terminal 8. The terminals 16, 19, 20, 21 and 22 were connected together. The terminals 13, 14, and 15 were connected together. Finally, terminal 11 was connected to terminal 12. One red covered alligator clip was attached to the free terminal of the connecting cables from position 12. One black covered alligator clip was attached to the free end of the cable from the position 22. This black alligator clip was also connected with an end of a new cable, and the other end of this new cable was attached to an uncovered alligator clip, which will connect the circuit to the ground.

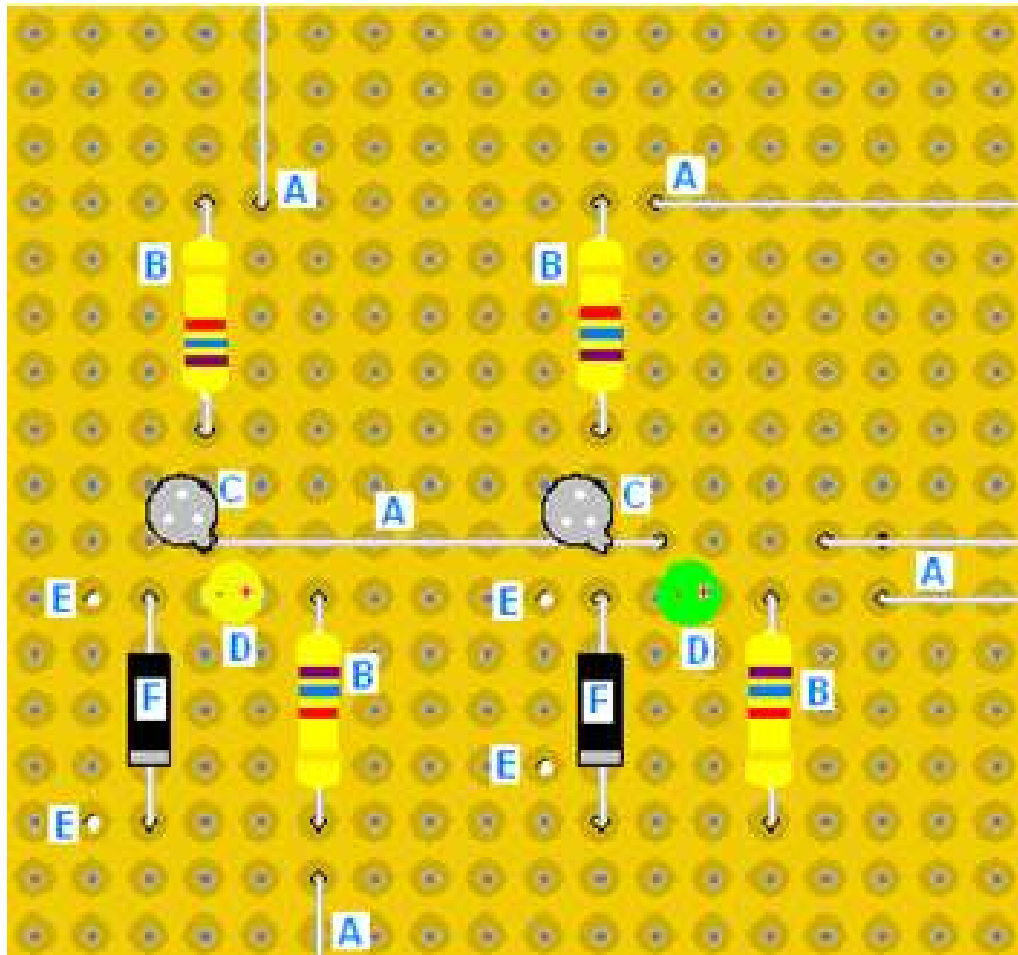

Figure 1.3: The component placement guide for a valve control circuit of the streaming potential device. A. Connection cables; B. Resistor 1 K ohm; C. Transistor NPN 30 V; D. LED; E. Male pin; F. Rectifier 1 A.²²

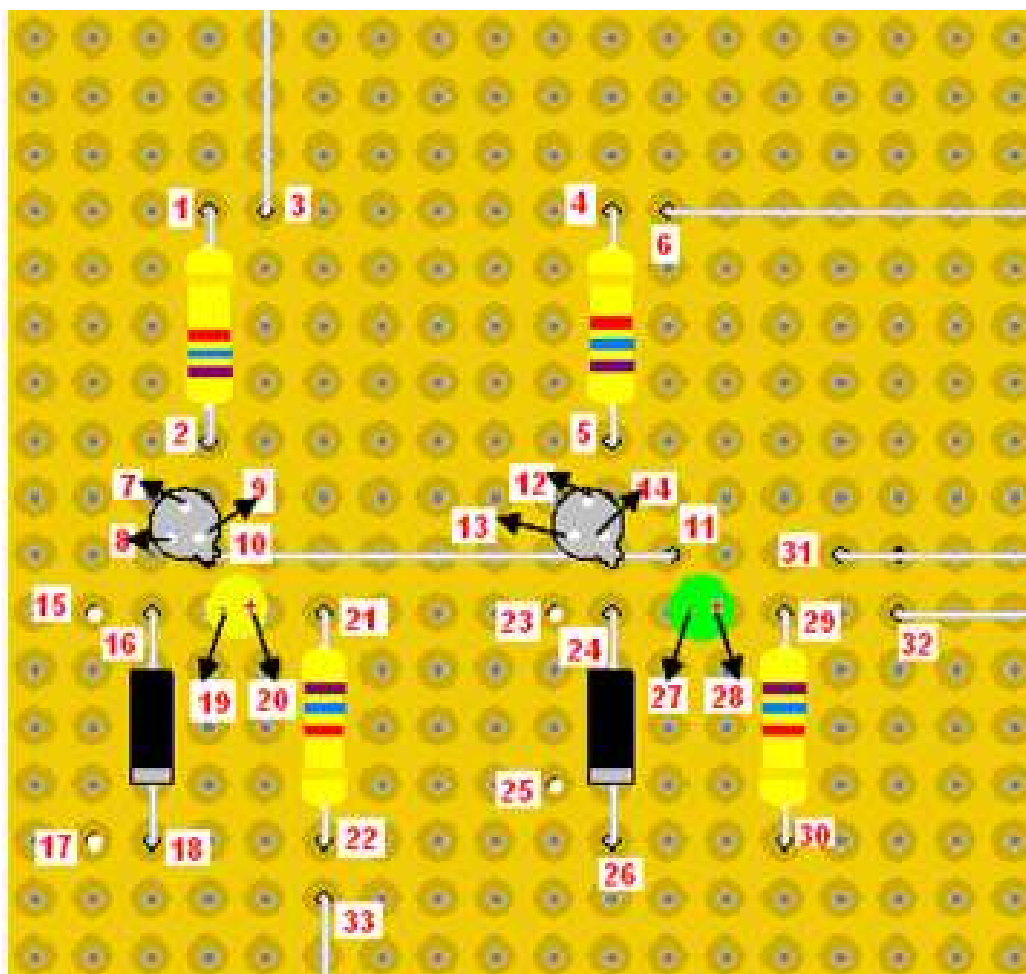

Figure 1.4: The terminal component guide 1 for the valve control circuit of the streaming potential device.²²

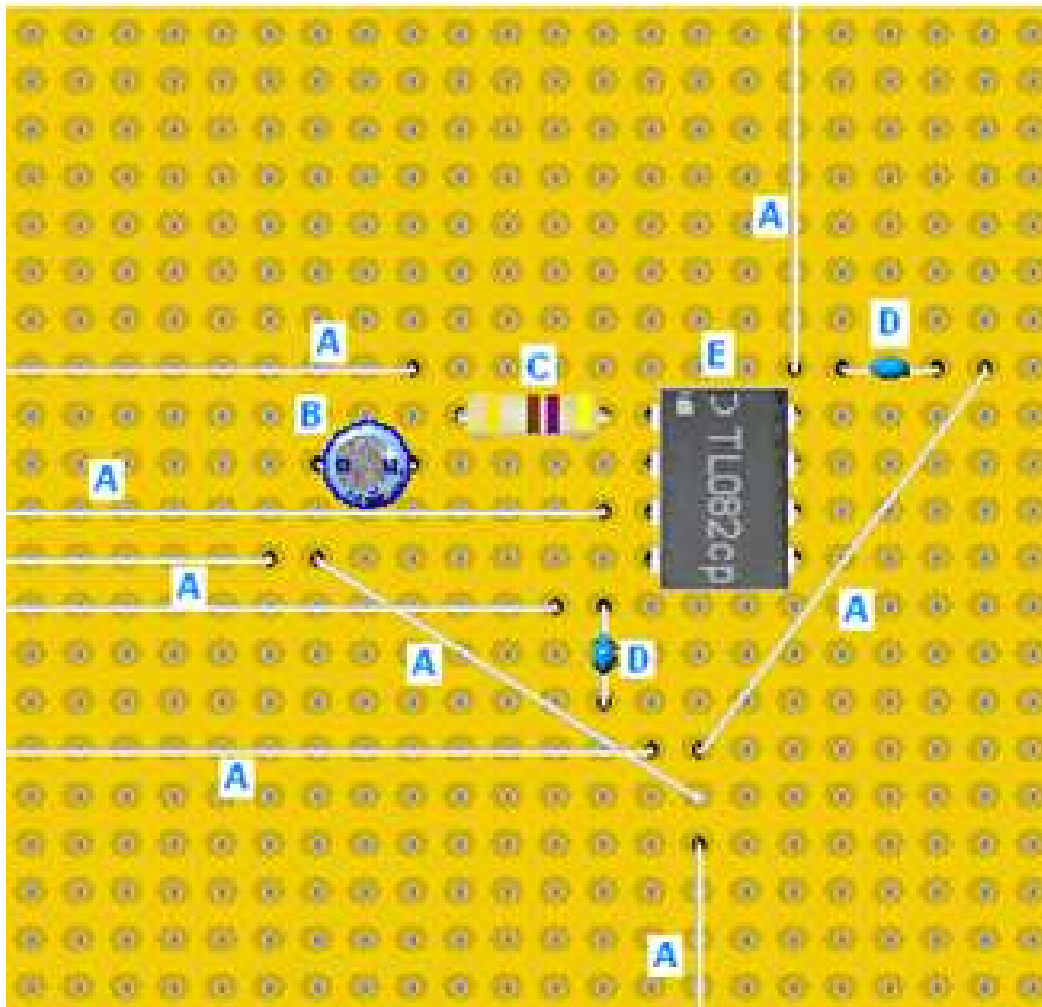

Figure 1.5: The component placement guide for the voltage follower circuit of the streaming potential device. A. Connection cables; B. Capacitor 3.3 μF ; C. Resistor 470 ohms; D. Ceramic capacitor 0.1 μF ; E. JFET operational amplifier.²²

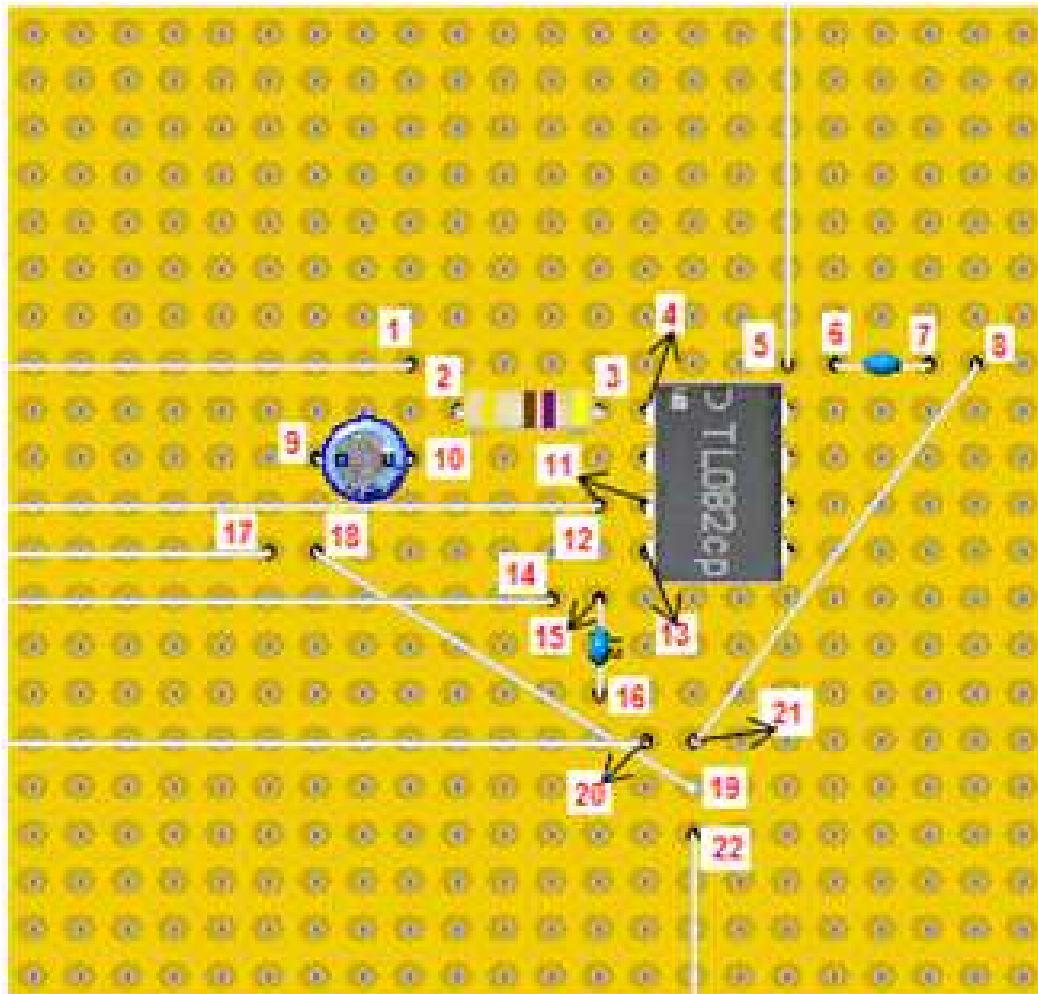

Figure 1.6: The terminal component guide 2 for the voltage follower circuit of the streaming potential device. ²²

1.2.1b- Construction of a liquid trap:

Materials: 50 mL plastic test tubes were products of Fisher Scientific (Pittsburgh, PA). 1 mL disposable syringes were purchased from Becton Dickson and Company (Franklin Lakes). Straight thru connectors, 500 Series Barbs 3/16" ID Tube (part number D1- ST074- 05), and Elbow connectors Classic Barbs 3/16" ID Tube (part number F1- EL042- 05) were purchased from Small Parts (Miami Lakes, FL).

Construction: A 50 mL plastic test tube, a 1 mL plastic syringe, a straight thru connector and an elbow connector were used. On the cap of the test tube, three holes were drilled. One size of a hole is equal to the size of the plastic syringe. One size of a hole is equal to the size of the straight thru connector, and the size of the other hole is equal to the size of the elbow connector. After the syringe, and the connectors were placed in the holes of the cap, epoxy glue were applied around the holes to seal the gaps. (Figure 1.7)

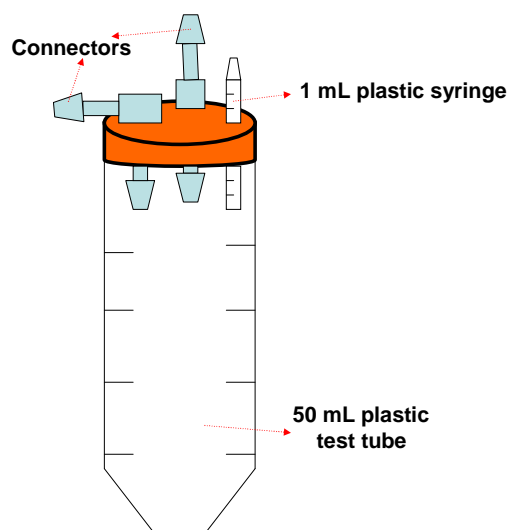

Figure 1.7: A liquid trap of the streaming potential machine

1.2.1c- Construction the of microchip holder:

Materials: A ¼" thick acrylic sheet was purchased from Small Parts (Miami Lakes, FL), syringe needles (25G 5/8) was purchased from Becton Dickson and Company (Franklin Lakes, NJ). PTFE #30 thin wall tubing (part number 06417- 11) was purchased from Cole Parmer (Vernon Hills, ILL. A 1/16" thick polycarbonate sheet (part number SPC-0062-C), Tubing Connector Barbed Tee 3/16" x 3/16" x 3/16" Tubing ID (part number TFN- BT187) and Straight Barbed 3/16" Tubing ID ¼- 18 NPT Pipe Thread (part number TFN- BAM 125/18) were purchased from Small parts (Miami Lakes). Pressure flexible tubing was purchased form local store.

Construction: For construction of microchip holder, an acrylic plate 1, an acrylic plate 2 and a polycarbonate electrode holder were made. To make acrylic plate 1, a 6 x 6 cm piece of acrylic plate was cut. Two equal sized holes, with the distance 4 cm were drilled on one side of the plate. To make acrylic plate 2, a 1.5 x 6 cm piece of acrylic plate was cut. Two holes, named 2-1, and 2-2, with the distance 4 cm were drilled. The sizes of the holes were equal to the sizes of the two holes on plate 1. At the middle of the plate, another hole, named 2-3, was drilled. A Straight Barbed 3/16" Tubing ID ¼- 18 NPT Pipe Thread was placed through the hole 2-3. Polycarbonate electrode holder was made by cutting a 1 x 4 cm polycarbonate piece. One 0.4 cm diameter hole was drilled at one terminal of the piece. Ten 0.2 cm diameter holes were drilled along to the length of the piece. The other electrode was held by a washer made by a circle of polydimethylsiloxane, PDMS. Since this washer would be placed between the Straight Barbed 3/6" Tubing ID ¼- 18 NPT Pipe

Thread and one end of the microchannel, the inside of the circle was cut so that the liquid can flow thoroughly from the channel to the Straight Barbed tubing. At the wall of the PDMS washer, a hole was made by a small needle and a 1 in. of platinum electrode was pushed through hole. One end of the electrode was inside of the circle, which would be contacted with one hole of the channel, and the other end was out side of the circle, which would be connected to the black alligator clip of the voltage follower circuit. After finishing, the components were put the together as described in Figure 1.8. One end of two long screws was stabled on the acrylic plate 1 through the two holes to make the bottom section of the microchip holder. For the top section of the microchip holder, the other end of the screws was placed through the two holes 2-1 and 2-2 of the acrylic plate 2. Since the diameter of the holes 2-1 and 2-2 were larger than the diameter of the screws, the acrylic plate 2 can move upward or downward along the screws. The 0.4 cm diameter hole of the polycarbonate electrode holder was placed over one screw and on the top of the acrylic plate 2. Since the diameter of the hole was greater than the diameter of the screw, the electrode holder could move around the screw. A Tubing Connector Barbed Tee, 3/6" x 3/6" x 3/6" Tubing ID was connected to the Straight Barbed 3/6" Tubing ID 1/4 -18 NPT Pipe Thread on the acrylic plate 2 by a flexible Tubing. The tip of a syringe needle (25G 5/8) was connected to 7.5 cm long PTFE #30 thin wall tubing. The PTFE #30 thin wall tubing was inserted inside the Tee and through the Straight Barbed 3/6" connectors. The plastic end of the needle was connected to flexible plastic tubing and was adjusted tightly to the Tee.

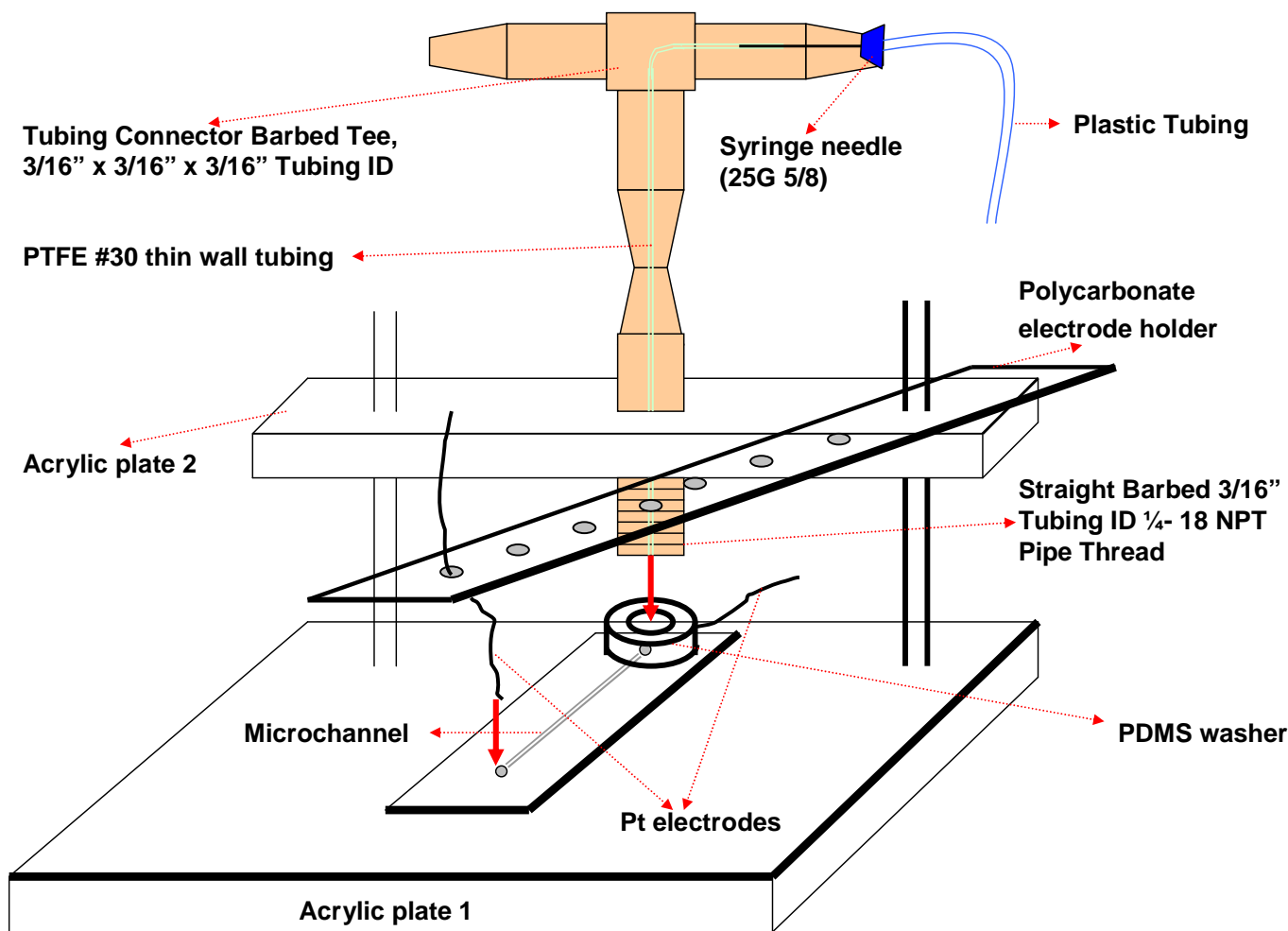

Figure 1.8: Schematic microchip holder

1.2.1d- A Faraday cage:

A metallic box (part number BW-98) was purchased from Mier Products Inc (Kokomo, IN) and was used to contain the microchip holder. The box also contained the voltage follower circuit and acted as a Faraday cage. On one side of the box, a 1.0 cm hole, a 0.5 cm hole, and three 0.2 cm holes were drilled for further use.

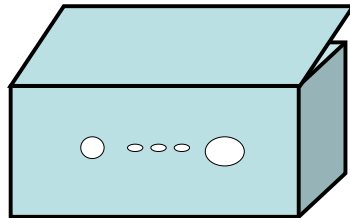

Figure 1.9: Metallic box that contains microchip holder and acts as a Faraday cage.

1.2.2- Construction of streaming potential machine:

1.2.2a-The pressure system:

Materials: An oil free pressure/ vacuum pump (model No. 2522B- 01) was purchased from Welch Vacuum Technology (Skokie, IL). Solenoid valves, stainless steel 3 ways 12 VDC (part number 01380-01) and 2 way normally closed 12 VDC (part number 05684-1) were purchased from Cole Parmer (Vernon Hills, IL). A valve control circuit and a liquid trap have been made.

Constructions: The vacuum outlet of the oil free pressure pump was connected to the straight thru connector of the liquid trap by a plastic tube. The plastic syringe on the cap of the liquid trap was connected to an outlet of the normally closed 12 VDC solenoid valve by a plastic tube. Another plastic tube was used to connect the elbow connector of the liquid trap to the outlet number 1 of the stainless steel 3 ways 12 VDC solenoid valve through a Barbed 1/16" tubing ID 10-32 UNF Pipe Thread. The black cables of the stainless steel 3 ways 12 VDC solenoid valve was connected to the Male pins at the positions 23 and 25 of the valve control circuit through the female connectors. The green cables of the normally closed 12 VDC solenoid valve were connected to the Male pins at the positions 15 and 17 through Female connectors.

1.2.2b- Streaming potential generation module:

Materials: A voltage follower circuit and a microchip holder have been made. The metallic box has four holes have been drilled.

Construction: The microchip holder and the voltage follower circuit were placed inside the metallic box. The uncovered alligator clamp was attached to the metallic box

(ground). At the top of the microchip holder, on one terminal of the Tubing Connector Barbed Tee, the free end of the flexible plastic tubing that had the other end attached to the syringe needle was connected to the free outlet of the normally closed 12 VDC Solenoid valve, and the other terminal of the Tee was connected to the free outlet of the Stainless Steel 3 ways 12 VDC Solenoid valve by a plastic tube through a Barbed 1/16" Tubing ID 10- 32 UNF Pipe Thread.

1.2.2c- Data acquisition and control:

The virtual instruments, named "Streaming potential with automatic valving. vi" and "Streaming potential calc from data file. vi," had been installed on a computer before.

A data acquisition card, (part product USB-1208 FS) was purchased from Measurement Computing (Norton, MA) and was connected to an USB port on the computer. The acquisition card was connected to the voltage follower circuit at following positions: The free terminal from position 17 of the circuit was connected to socket No 2 of the acquisition card, and the free terminal from position 1 was connected to socket No 1 of the acquisition card. Also, the acquisition card was connected to the valve control circuit at 3 positions which are socket No 24 connected to the free terminal from position 3 of the circuit; socket No 21 connected to the free terminal from position 6; and socket No 31 connected to the free terminal from position 31 of the circuit.

1.2.2d- Power supply:

A HiPro HP-M1854F3P power supply was purchased from Beach Computer (Satellite Beach, FL). The P6 connector of the power supply was connected to the valve control circuit as illustrated in figure 1.8. The P1 connector of the power supply was connected to the voltage follower circuit as illustrated in figure 1.9. To turn on the power

supply, a short cable was used to connect the third and the fifth sockets, on P1, bottom row, from right to left.

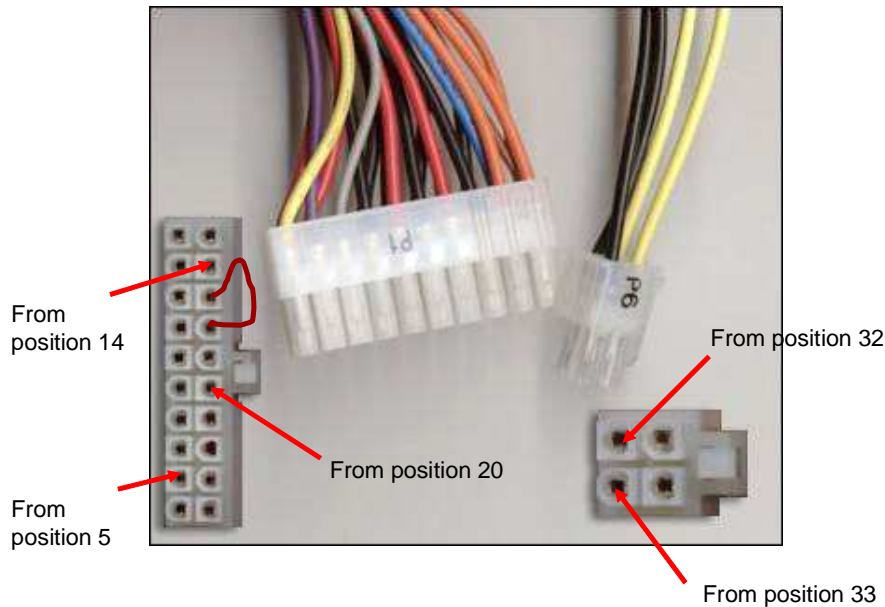

Figure 1.10: A. Connections for the valve control circuit to power supply. B. Connections for the voltage follower circuit to power supply.

1.2.2e- Operation of streaming potential measurement:

To measure streaming potential of a microchannel, the channel was placed on the acrylic plate 1 of the microchip holder. The PDMS washer was placed on the top of the channel so that the platinum electrode on the washer would contact with the hole of the channel. The straight barbed tubing was placed on the top of the PDMS washer, and then, the crews were tightened to keep the channel stay on its position. One end of a 5 cm piece of platinum electrode was attached to the red alligator clamp, and the other end of the electrode was contacted with the free end of the channel. The black alligator clip was

connected to the electrode on the PDMS washer (Figure 1.8). The liquid sample was injected inside the channel as a drop covering the hole of the channel which was connected to the electrode on the red alligator clamp while the vacuum was pumping.

CHAPTER 2:

Development of a lab experiment for undergraduate and high school chemistry

2.1- Introduction:

In this chapter, an experiment created for undergraduate or high school labs will be described. By doing this experiment, students can learn such useful concepts as physical adsorption on non porous surfaces, surface charge, and electrochemical potentials. During the experiment, they can learn to measure pH, conductivity, prepare solutions, collection and analysis of data. This process can improve their analytical and problem solving skills. The experiment is suited for school labs because of the low cost instrumentation, it is easy to operate, and is safe for students. In addition, the chemicals used are inexpensive and not hazardous. The experiment time can be divided into two parts with 2 hour lab for each section. The first part could be the fabrication of microfluidic chips and the modification of the microchannel surface with polyelectrolyte solutions. The second part could be making buffer solutions and measuring streaming potential. Home work after the two sections involves the calculation and plotting of Zeta potential graphs. The Zeta potential is calculated from the streaming potential measurement by using the Smoluchowsky equation (Eq. 1):^{1,22}

$$\zeta = \frac{\eta \lambda}{\epsilon} \times \frac{\Delta E}{P} \quad (\text{Eq. 1})$$

In equation 1, ζ is the Zeta potential in volts, η is the solution viscosity in Pascals- second (Pa-s), λ is the conductivity of buffer solution in Siemens per meter (S/m), ϵ is the dielectric permittivity, ΔE is streaming potential (V), and P is pressure (Pa). If the applied pressure, dielectric permittivity, viscosity, and conductivity of the solution are kept constant, streaming potential will depend mostly on the Zeta potential. It has been known that if the surface charge density changes, the Zeta potential will change as well.¹⁵ As a result, the streaming potential will change. The magnitude and sign of streaming potential

is proportional to the magnitude and sign of Zeta potential.^{6, 15} Because of this relationship, if a charged channel surface is modified by a species of opposite charge, a reverse streaming potential or Zeta potential will be observed. It also has been known that Zeta potential is heavily dependent on pH because protonation can change the charge of some chemical functionality.^{23,24,25} A plot of Zeta potential versus pH could be positive or negative depending on how the surface charge changes with the pH. The value of pH at which Zeta potential is equal to zero can be thought of an isoelectric point for the surface, in which the net surface charge is zero in analogy to the same concept used for proteins.⁶ In order to observe a reversal of the Zeta potential as well as the streaming potential in microchannels made by polycarbonate (PC), three surface modifiers were chosen. The first one was poly(allylamine) hydrochloride (PAH) (Scheme 2.1), which is a cationic polyelectrolyte highly soluble in water.

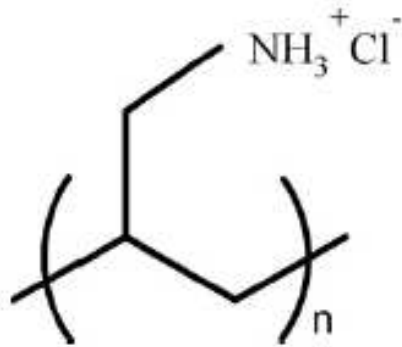

Scheme 2.1: Structure of Poly(allylamine) hydrochloride, PAH.

The second modifier is poly(sodium 4-styrenesulfonate) (PSS) (Scheme 2.2), which is an anionic polyelectrolyte and also very soluble in water because it is the sodium salt of polystyrene sulfonic acid.²⁶ Both PAH and PSS have been used for preparing multilayer films of a desired composition and functionalities.^{27,28,29,30,31,32,33}

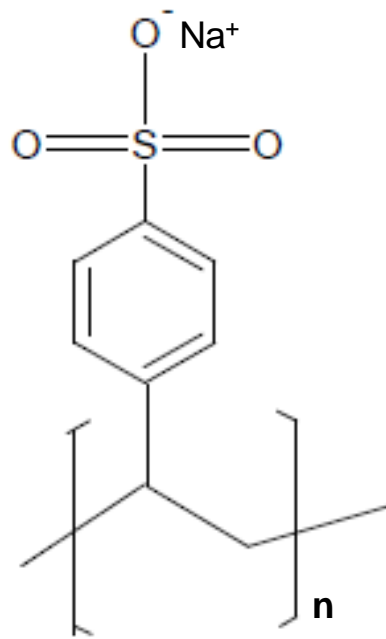

Scheme 2.2: Structure of poly(sodium 4-styrenesulfonate), PSS.

The third modifier used for this work was Bovine Serum Albumin, (BSA), which is a protein with high nonspecific adsorption affinity and has an isoelectric point (PI) of 4.7-5.^{34,35,36,37,38,39} These three modifiers were used to impart three different charge patterns in the polycarbonate channels. Polycarbonate, (Scheme 2.3), is inexpensive and commercially available.

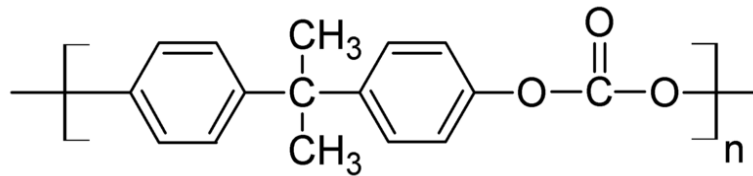

Scheme 2.3: Structure of polycarbonate

2.2- Experimental section:

2.2.1-Chemicals:

Polycarbonate (PC) (LEXAN) sheet (0.062" thick) and stainless steel wire 0.005 in. (127 μm in diameter) were purchased from Small Parts. Micro slides of glass (3"-1" Plain) were ordered from Corning Glass Works. Poly (allylamine hydrochloride) (PAH) was ordered from Aldrich. Poly (styrene sulfonate) sodium salt (PSS) was ordered from Scientific Polymer Products. Bovine serum albumin (BSA) was ordered from SIGMA. Dibasic sodium phosphate and mono basic sodium phosphate were from EM Chemical (Gibbstown, NJ). Eighteen M Ω DI water obtained from a Milli-Q purification system (Millipore, Billerica, MA).

2.2.2- Fabrication of Microfluidic chips:

To make one Polycarbonate chip, two PC sheets, A and B, 2 by 0.7 inches were cut. The stainless steel wire was cut short to 1.5 inches long. The two pieces of PC and 2 glass micro slides were cleaned with ethanol and dry by air to remove dust and contaminants. The stainless steel was placed on one of the PC pieces, piece A, and sandwiched between the two glass micro slides using 4 small binder clips. The other PC piece, piece B, was also sandwiched using the same process but without the stainless steel wire. After that, both of the sandwiches were put in an oven at 165 °C in 15 minutes. Then they were taken from the oven and allowed to cool down. The plastic pieces and the micro slides were detached and the wire was pulled away to get a semicircular empty channel on piece A. Two holes located on piece B were drilled. The distance between the two holes was

equal to the length of the final channel on piece A. The two PC pieces were sonicated in ethanol for 10 minutes. After dried, the two PC pieces were assembled together with holes aligned along the channel and sandwiched between two glass micro slides clamped by 6 binder clips. The sandwich was put in the oven at 150 °C in 15 minutes to seal the chip.

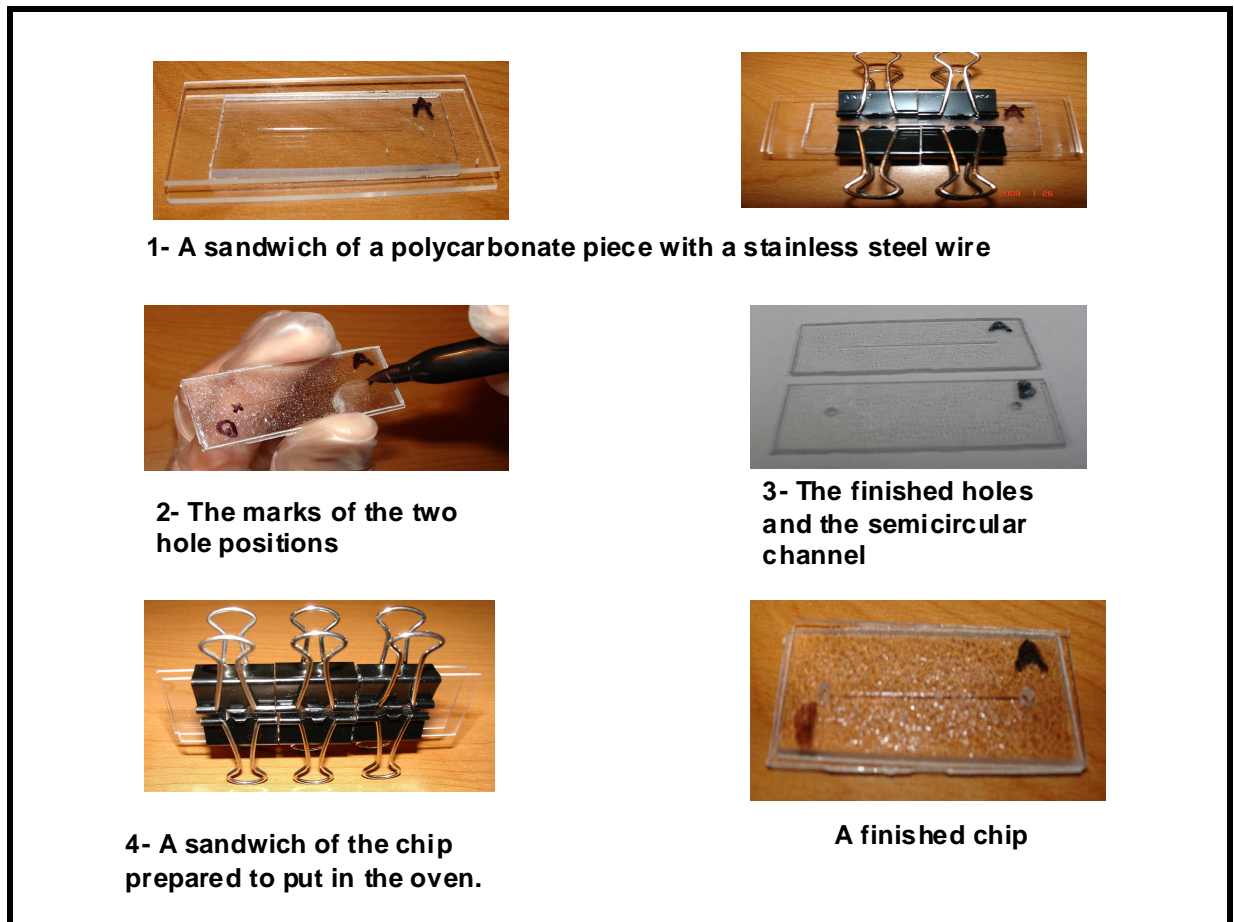

Figure 2.4: The process of polycarbonate microchannel fabrication.

2.2.3- Modification of PC microchannels:

2.2.3a- Modification of PC channels by PAH and PSS:

A small piece of plastic tube was cut and attached on the tip of a 1 mL plastic syringe and used as a solution injector. 5.0 mM PAH in DI water was pushed inside the microchannel by the syringe and left for 5 minutes to allow the adsorption of the solution on the surface of the channel. Then the excess solution was washed out of the channel by pushing DI water through the channel 10 times. Modification of PC microfluidic channel by PSS was done using the same process with 0.2 mM PSS.

2.2.3b- Modification of PC channel by BSA:

A PC chip was placed on the microchip holder as would be described in the following section of streaming potential measurement. BSA 43mg/ml solution was flush through a PC microfluidic channel for 60 s using the streaming potential device with pulses pressure at 60 cm Hg.

2.2.4- Preparing buffer solutions:

Four solutions A, B, C, and D were prepared as follows: A was 10.0 mM H_3PO_4 solution, B was 20.0 mM NaH_2PO_4 , C was 10.0 mM Na_2HPO_4 , and D was 10.0 mM Na_2HPO_4 with 10.0 mM NaOH. Buffer solutions with different pHs were made by mixing solutions A, B, C, and D as indicated in Table 1 with DI water to reach 10.0 mL and their conductivity was adjusted with NaCl.

Table 1: The amount of solutions A, B, C, and D needed to mix with DI water to make 10.0 mL buffer solutions with different pH.

Solution number	A (μL)	B (μL)	C (μL)	D (μL)	Conductivity ($\mu\text{s/cm}$)	pH
1	590				196	3.1
2	120	1100			193	3.7
3		1310			199	4.6
4		1160	120		192	5.5
5		380	752		216	6.8
6		60	1010		203	7.5
7			950	50	193	8.2
8			790	140	196	9.0
9				510	187	10.1

2.2.5- Streaming potential measurements of modified microchannels:

Streaming potential measurements of PC- modified microchannels were taken with the streaming potential instrument described in the previous chapter. Buffer solutions with different pH were prepared according to Table 1. The channel fill time was 2 s; the time for the suction ON was 2 s; and the time for the valve on the OFF position was also 2 s. Each value of streaming potential reported was the average of 5 times readings. Measurement of modified channels were done by keeping the pressure constant at 60 cm Hg while changing the pH of the buffer solutions from pH 3.1 to pH 10. To test the dependence of streaming potential on pressure, streaming potential of channels modified by PAH and channels modified by PSS were taken by buffer pH 7.5 and pressure changing from 5 cm Hg to 60 cm Hg.

2.2.6- Calculation of Zeta potential from resulting streaming potential measurements at different pH and constant pressure.

The Zeta potential is calculated using Eq. 1

$$\zeta = \eta \lambda / \varepsilon \times \Delta E / P \quad (\text{Eq. 1})$$

The pulses of pressure were at 60 cm Hg, which corresponds to 79993.422 Pa. The value of different pH and conductivities are shown in Table 1. The temperature of buffer solutions was 23 °C. The results of the calculation were in Table 2 with bare polycarbonate chip (PC), PC chip modified by poly(allylamine) hydrochloride (PC-PAH), PC chip modified by poly(sodium 4-styrenesulfonate), (PC-PSS), and PC chip modified by Bovine Serum Albumin, (PC- BSA).

2.3- Results:

Table 2: The Zeta potential calculated from the streaming potential

		PC- PAH		PC- PSS		PC- BSA		PC	
pH	λ (S/m)	ΔE (V)	ζ (V)	ΔE (V)	ζ (V)	ΔE (V)	ζ (V)	ΔE (V)	ζ (V)
3.1	0.017	0.30	0.084	- 0.21	- 0.058	0.23	0.064	- 0.25	- 0.070
3.7	0.019	0.19	0.060	- 0.22	- 0.072	0.12	0.038	- 0.18	- 0.059
4.6	0.020	0.14	0.047	- 0.25	- 0.081	0.036	0.012	- 0.16	- 0.053
5.5	0.019	0.096	0.031	- 0.22	- 0.071	- 0.066	- 0.021	- 0.16	- 0.052
6.8	0.022	0.050	0.018	- 0.24	- 0.085	- 0.16	- 0.057	- 0.21	- 0.077
7.5	0.020	0.041	0.014	- 0.24	- 0.082	- 0.18	- 0.060	- 0.27	- 0.090
8.2	0.019	0.046	0.015	- 0.25	- 0.080	- 0.20	- 0.062	- 0.30	- 0.097
9.0	0.020	0.060	0.020	- 0.25	- 0.082	- 0.20	- 0.063	- 0.30	- 0.099
10.	0.019	0.027	0.0085	- 0.28	- 0.087	- 0.21	- 0.066	- 0.32	- 0.10

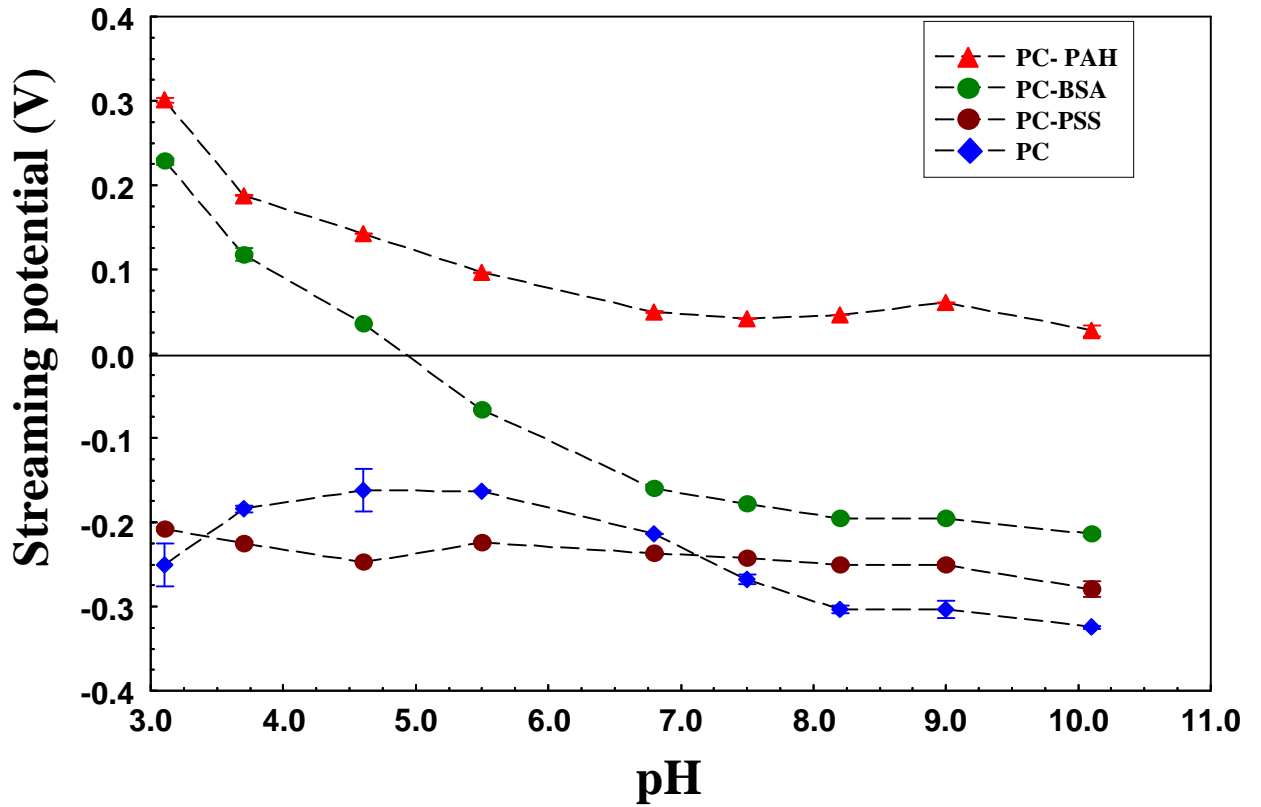

Figure 2.5: Pulsed streaming potential, ΔE , as a function of pH for polycarbonate channel modified by poly(allylamine) hydrochloride, (PC-PAH), for polycarbonate channel modified by poly(sodium 4- styrenesulfonate), (PC-PSS), for polycarbonate channel modified by bovine serum albumin, (PC-BSA), and for bare polycarbonate channel. The conductivities of phosphate buffer solutions were from 187- 216 $\mu\text{S}/\text{cm}$. Pulsed pressure was 60 cm Hg.

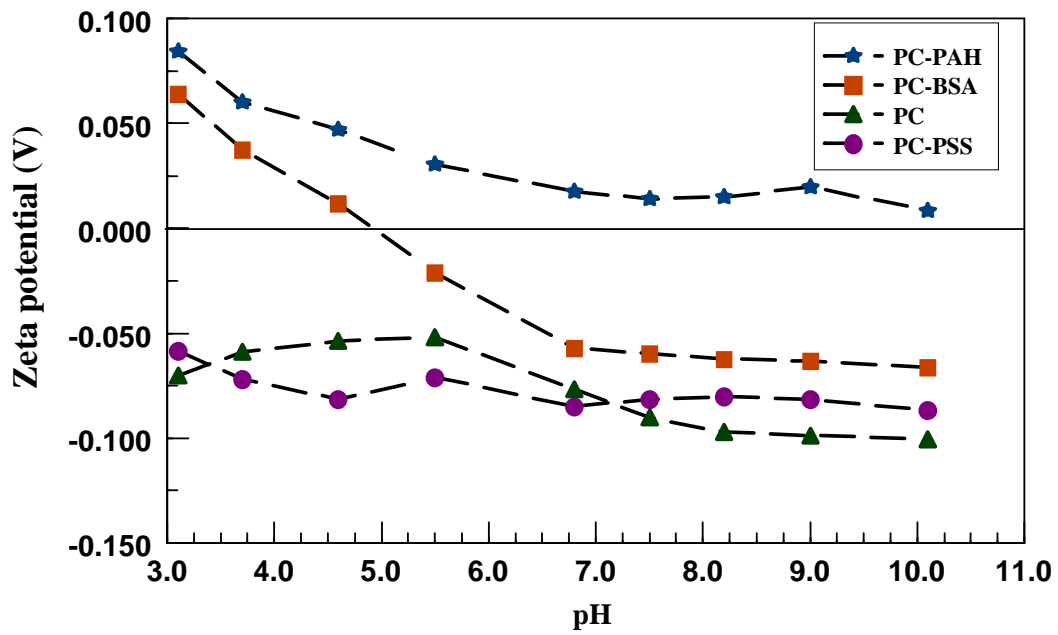

Figure 2.6: The Zeta potentials, calculated from the streaming potentials in Figure 2.5, as a function of pH. The temperature of buffer solutions was 23 °C. Pulsed pressure was 60 cm Hg.

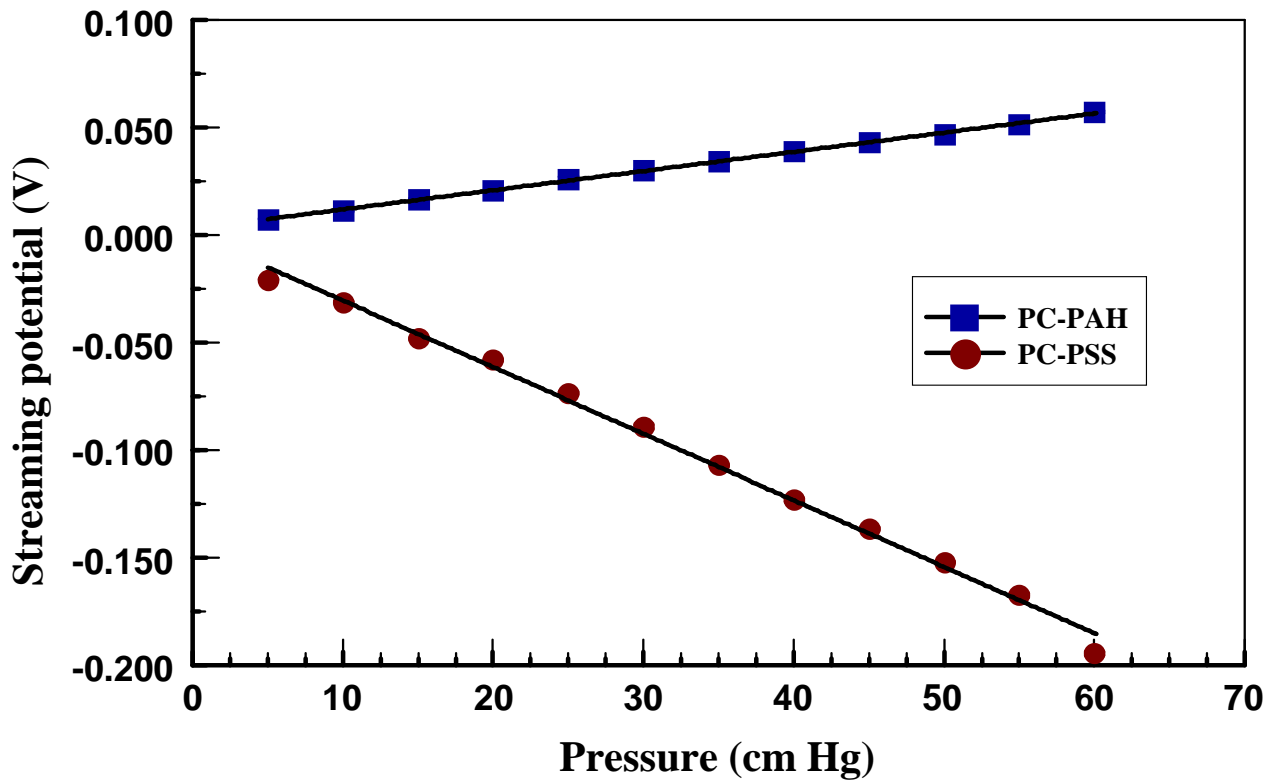

Figure 2.7: Pulsed streaming potential of polycarbonate channel modified by poly(allylamine) hydrochloride, (PC-PAH), and polycarbonate channel modified by poly(sodium 4-styrenesulfonate), (PC-PSS), taken at different pressure. The buffer solution was at pH 7.5 (0.06mL NaH₂PO₄ 20mM + 1.010 mL Na₂HPO₄ 10mM + 8.93 mL DI water). The conductivity of the solution was 203 μ S/cm. The temperature of the solution was 23 °C.

2.4- Discussion:

2.4.1- Streaming potential and Zeta potential dependent on pH:

Figure 2.4 shows a series of streaming potential vs. pH curves. Streaming potential of the bare PC channel (blue squares) indicates that the charge density at the electric double layer of bare PC is always negative at the evaluated pH range, (pH 3.1 to pH 10.0). When the PC channels were modified with anionic polyelectrolyte PSS, the streaming potential changes (pink circles). Even though the changes are not very significant, it indicates the non specific adsorption of PSS on PC surface. The calculated Zeta potential of PSS modified channel ranges from -0.058 V to -0.087 V (Table 2). This result is similar to the Zeta potential calculated from the streaming potential of PSS modified surface taken by the streaming potential method in the parallel- plate channel set up.²⁰ The streaming potential vs. pH curve shows that the charge density at the EDL of PC-PSS channel is always negative regardless of changing pH. Alternatively, the streaming potential of PC- PAH channel is always positive at the chosen pH range (red triangles) (Figure 2.4).The adsorption of cationic PAH on the surface actually causes the positive charge development at the EDL of the channel surface. The calculated Zeta potential of PC- PAH channel ranges from 0.0085 V to 0.084 V (Table 2). This result is also similar to the calculated Zeta potential of PAH modified channel taken by the parallel- plate channel set up.²⁰ With the adsorption of BSA on PC channel surface, the negative streaming potential of PC surface shifted to positive and went down to negative with the isoelectric point at pH~5 which is similar to the result reported in previous studies.^{34- 39} The change in streaming potential of PSS modified channel, PAH modified channel and BSA modified channel actually give evidence for the adsorption of these molecules on non porous PC surface. This adsorption is not caused by chemical bonds as

in chemical adsorption. Instead, this is an evident for physical adsorption. The Zeta potential vs. pH curves (Figure 2.5), especially the PC- BSA curve, indicates the dependence of Zeta potential on pH. At low pH, the Zeta potential is positive, which shows that the positive charge is dominated at the EDL. When the pH goes up, which means the OH^- concentration in solution is going up. So the positive charge at the EDL is neutralizing. At the pH of isoelectric point, the Zeta potential is zero, which means that the positive charge of the EDL is totally neutralized. Then, at higher pH, the negative charge is dominated, so the Zeta potential goes down to negative values.

2.4.2- Streaming potential dependence on applied pressure:

Figure 2.6 shows the linear relationship of streaming potential and applied pressure. At pH 7.5, streaming potential of PC- PSS channel is negative and PC- PAH channel is positive. When the applied pressure is increased, the streaming potential of PC- PAH channel is more and more positive, while the streaming potential of Pc-PSS channel is more and more negative. This indicates that streaming potential is proportional to the pressure as illustrated in the Smoluchowsky equation.

2.5- Conclusion:

The experiment is useful for high school and undergraduate students. By doing the experiment, students can learn that besides chemical adsorption, nonporous surface can process physical adsorption. The experiment results show for linear relationship of streaming potential and applied pressure, and the dependence of streaming potential on pH. As in Smoluchowsky equation, if the viscosity, conductivity, dielectric constant, and applied pressure are kept constant, streaming potential is dependent on Zeta potential. So, if channels are modified by different charged species, the opposite charge development on EDL will cause the opposite sign of Zeta potential as well as of streaming potential. This reverse of streaming potential can be detected by our streaming potential device and these phenomena can be used as an output signal for detection technique as illustrated in the next chapter.

CHAPTER 3:
Heparin detection

3.1-Introduction:

In this chapter, the detection of heparin by protamine immobilized on Polycarbonate and on Cyclic Olefin Copolymer surfaces is investigated. Heparin, (Scheme 3.1) is a highly- sulfated glycosaminoglycan, which is a long, unbranched polysaccharide with a repeating disaccharide unit.⁴⁰ The molecular weight of heparins ranges from 5,000 to 30,000 Da. Heparin is often used as an anticoagulant to prevent blood clotting during cardiac surgery, as well as to treat post- operative thrombosis and embolism.^{41,42,43,44} It is necessary to monitor the concentration of heparin in the blood not only during the surgery but also after the surgery since an excess amount of heparin can cause serious bleeding problems for the patients.⁴⁵ Plasma heparin concentrations have been commonly monitored by two techniques, the activated clotting time (ACT) or the activated partial thromboplastin time (APTT).^{46, 47} It is reported that the results from these methods are not specific for only heparin amount.^{46, 48} So, there is still the need to develop applicable heparin sensors. The heparin doses used for cardiac surgery range is from 2 to 8 units/mL and the therapeutic concentration range of heparin is 0.2 - 0.7 units/mL.⁴⁹ Here we report a method that can detect heparin concentration in the range of 0.00074 - 0.074 units/mL at pH 7.5. In our method, adsorbed protamine on polycarbonate (PC) and Cyclic Olefin Copolymer (COC) microchannels was used as a heparin receptor. Pulsed streaming potential measurements of the modified channels are the output signal for the adsorption of heparin on protamine surfaces. Protamine is routinely used to neutralize the anticoagulant activity of heparin after heart surgery due to electrostatic complexation of protamine and heparin functional groups.^{50, 51} Protamine is a highly cationic molecule.⁵² The adsorption of protamine on PC and COC microchannel surfaces will result in the development of positively charged surfaces, which can be detected by streaming

potential. At pH 7.5, heparin is negative charged because of the ionization of sulphate and carboxylate.⁵³ After the binding of heparin and protamine occurs, negative charge will dominate on the channel surfaces and a reversal of the streaming potential will be continuously monitored. This work is an extension of previous studies in our group. We have reported the label- free detection of heparin by pulsed streaming potentials in COC microchannels.⁵⁴ By the variation of streaming potentials vs. different concentration of heparin, we could detect heparin concentrations as low as ~ 0.01 units/mL. Recently, we have reported real time monitoring of Lysozyme (Ly) adsorption on the surface of COC microchannels.⁵⁵ Initial adsorption rates were announced to have a linear correlation with the bulk concentration of Ly in the range between 7.0 to 350 nM. By the same token, in this work, initial adsorption rates of heparin on plastic channels modified by protamine are found to have linear relationship with the bulk heparin concentrations in the range of 0.00074 - 0.074 units/mL. By using this strategy, we can detect heparin at lower concentration than what we have reported before. Also, the detection results on PC and COC substrates will be compared.

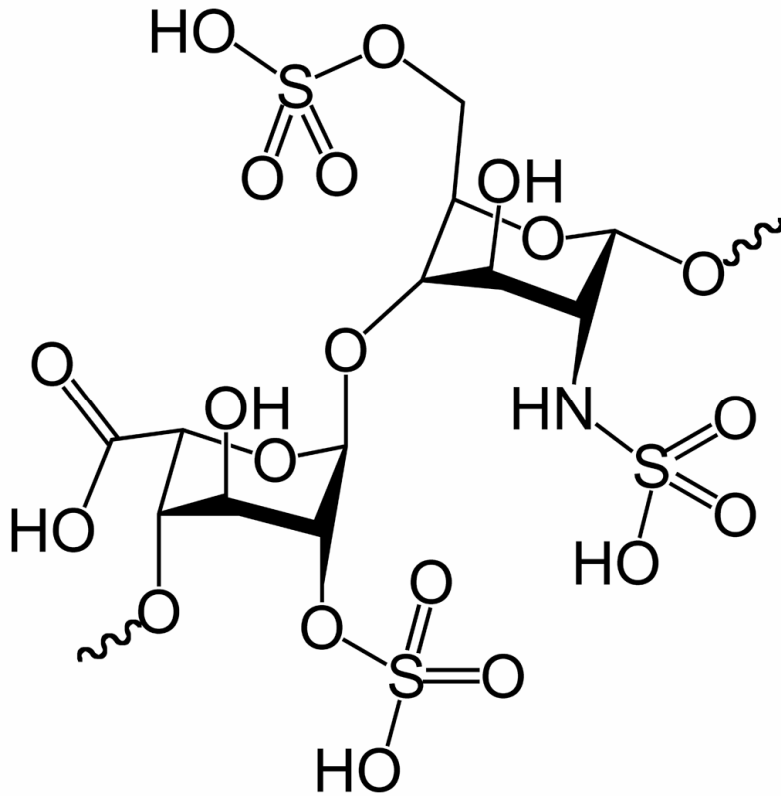

Scheme 3.1: Structure of heparin

3.2- Experimental section:

3.2.1- Chemicals:

Cyclic olefin copolymer (COC) resin (Topas 8007 × 10, with the glass transition temperature of 80 °C) was purchased from Ticona (Florence, KY). Polycarbonate (PC) (LEXAN) sheet (0.062” thick) was purchased from Small Parts (Miami Lakes, FL). Dibasic sodium phosphate and mono basic sodium phosphate were from EM Chemical (Gibbstown, NJ). 18 MΩ DI water was obtained from a Milli-Q purification system (Millipore, Billerica, MA).

3.2.2- Fabrication of Microfluidic Chips:

The fabrication of PC microchannels was done as described in chapter 2. COC microchannels were made by the same process with PC channels but using a different oven temperature as reported elsewhere.⁵⁴ The oven temperature for imprinting COC channel by the wire method was 120 °C and for sealing the chip was 80 °C.

3.2.3- Modification of microchannels by protamine:

Protamine was adsorbed on COC and PC microchannels by flushing 0.1 mg/ml of protamine in phosphate buffer solutions for 15 seconds, using the streaming potential device. Channel is set up on microchip holder; Pulsed pressure at 60 cm Hg was used. The valve control vacuum is opened for 15 second for the absorption and closed for 1 second. Waste removal time is 3 seconds.

3.2.4- Adsorption of heparin on protamine modified PC channels and on protamine modified COC channels:

After flushing 0.1 mg/mL protamine solution to modify a PC or a COC microchannel, phosphate buffer pH 7.5 solution without heparin was flushed through the

channel in 20 seconds to wash the excess amount of protamine and to measure the streaming potential of the initial protamine surface. In these 20 seconds, five values of streaming potential were recorded. The last value was taken as the initial value at 0 second of heparin adsorption. Then, a solution of phosphate buffer with a known heparin concentration was pushed through the modified channel for 200 seconds. Streaming potential was recorded every two seconds during heparin adsorption. The same process was applied for different heparin concentrations, ranging from 0.00037- 0.11 units/mL and for both kinds, PC and COC, of microfluidic channels. All solutions were at pH 7.5 and at conductivities of $397 \pm 1 \mu\text{S/cm}$. Pulses of pressure were constant at 60 cm Hg. The streaming potential of protamine- modified COC channels by phosphate buffer solution without heparin were also taken in the same process as control experiments.

3.3- Results and discussion:

3.3.1- Adsorption of protamine on COC and PC surface:

In order to find appropriate concentration of protamine to modify the microfluidic channels, different concentrations of protamine in phosphate buffer pH 7.5 were flushed through COC channels. Pulsed pressure was 60 cm Hg. Streaming potentials were taken every 2 seconds. Figure 3.1 shows variation of streaming potentials, indicating charge density levels achieved by adsorption of protamine at different concentrations. Bare COC curve shows negative streaming potentials, proving that COC is a negative charged surface at pH 7.5. This agrees with what have been reported in our previously studies.^{54,}⁵⁶By raising protamine concentrations, the streaming potential gradually increases and shifts to positive. The streaming potential at saturated adsorption increases with

protamine concentration, indicating increased positive charge density on the surface. More over, at high concentration, (> 0.010 mg/mL), the streaming potentials remain the same regardless of increasing protamine concentrations. With protamine 0.10 mg/mL, the highest positive streaming potential is achieved immediately.

Figure 3.2 shows the adsorption and desorption of protamine on COC, and PC channels. Protamine in phosphate buffer solution was spontaneously and irreversibly adsorbed on COC and PC channel walls. Washing was done by protamine- free phosphate buffer solution. Streaming potential was taken every two seconds during adsorption and desorption. It is observed that after washing, the streaming potential slightly decreases, for example from 0.071 - 0.066 (V) after 20 seconds, and then becomes almost constant, for example around 0.063 - 0.059 (V) after 200 seconds of washing. Compare to the negative bare COC and PC channels, which have streaming potential around $- 0.13$ (V), the remained surfaces after washing are still highly positively charged, and the constant streaming potential indicates the stability of the adsorbed protamine layer. In vivo, the inactivation of heparin (anionic specie) by protamine (cationic one) has been well known.⁵⁷ With stable positive charged surfaces; protamine- modified COC and protamine- modified PC channels are relevant for sensing purposes. Figure 3.2 shows similar behaviors of streaming potentials obtained by COC and PC. So, either using COC or PC substrate, a stable protamine- modified surface can be achieved. An advantage of this technique is that it is a very simple physical adsorption process. It does not need a long incubation time. In this work, we use 15 seconds for modification. Previous studies spent 30 minutes,⁵⁸ 20 minutes,⁴⁸ or 24 hours.⁵⁹ In addition, the amount of protamine used is very small, about 50 μ L of 0.10 mg/mL protamine per channel.

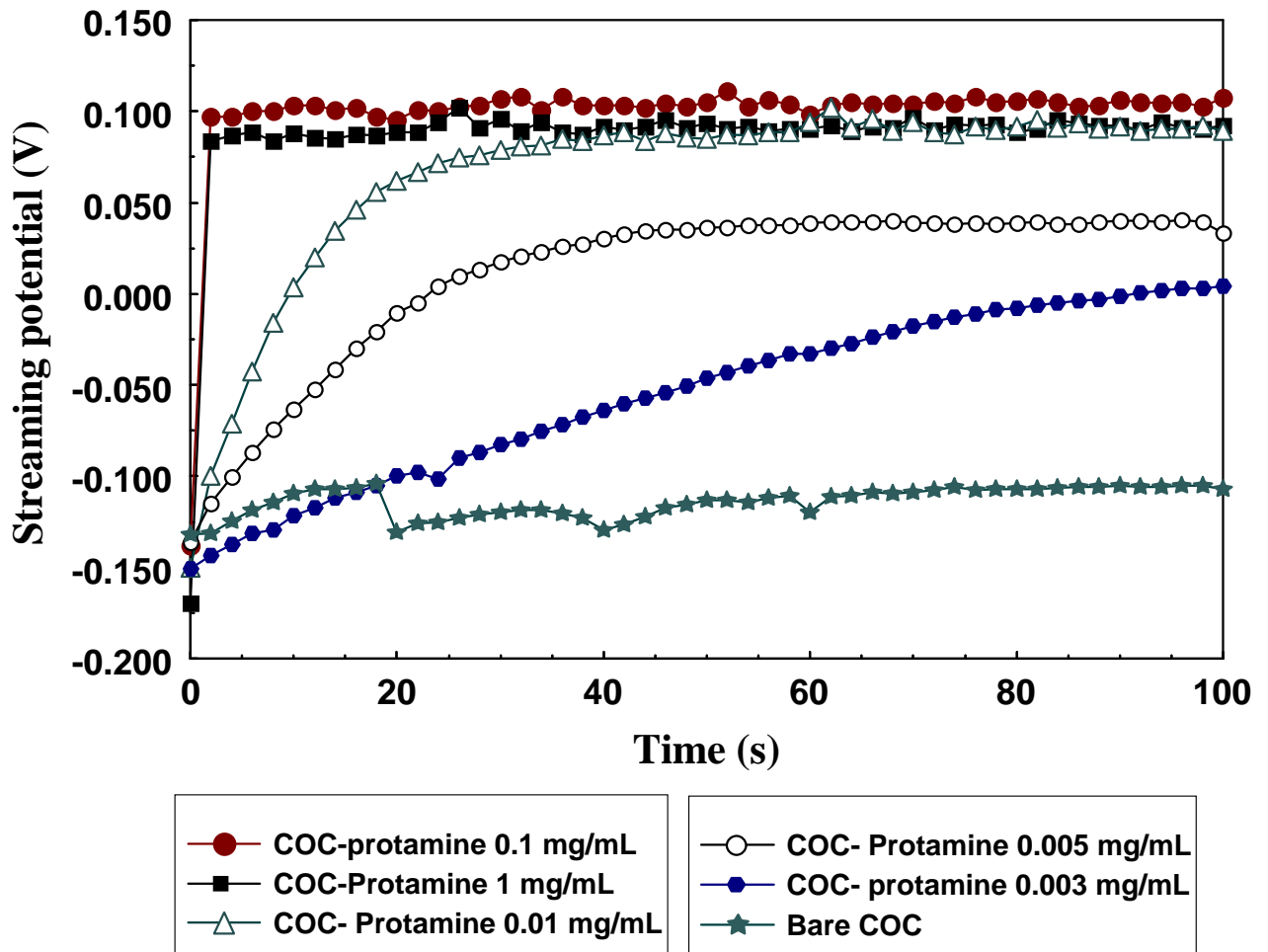

Figure 3.1: Variation of streaming potentials taken by flushing phosphate buffer, pH 7.5 without protamine, (Bare COC) and with different protamine concentrations, (COC-Protamine) through Cyclic Olefin Copolymer (COC). Pulsed pressure was at 60 cm Hg. Constant conductivity was $397 \pm 1 \mu\text{S}/\text{cm}$.

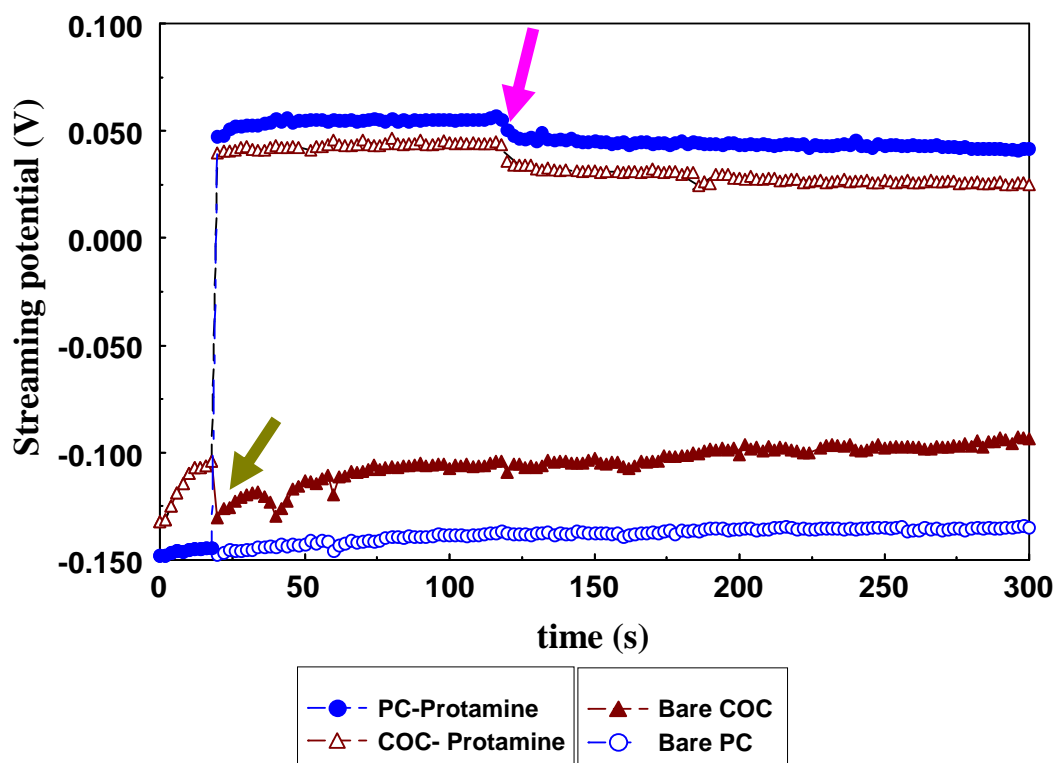

Figure 3.2: Variation of streaming potentials of Cyclic Olefin Copolymer (COC), and polycarbonate (PC), channels, taken by flushing protamine- free phosphate buffer solution, (Bare PC, and Bare COC), and with protamine phosphate buffer solution, (PC-protamine, and COC- protamine). Washing was done by flushing free- heparin phosphate buffer solution. Pulsed pressure was at 60 cm Hg. All solutions are at pH 7.5 and at conductivity $397 \pm 1 \mu\text{S}/\text{cm}$. The green arrow indicates protamine injection moment; pink arrow indicates washing moment.

3.3.2- Comparison protamine- modified COC and protamine- modified PC surfaces:

To compare the protamine- modified COC and protamine- modified PC surfaces, four modified PC chips and four modified COC chips were tested. Phosphate buffer pH 7.5 was flushed for 60 seconds to wash the surface and to measure the streaming potentials. The slopes of the streaming potential vs. time curves were determined. For COC modified chips, the 95% confidence interval of the slopes is $- 0.00013 \pm 0.00006$. For PC modified chips, the 95% confidence interval is $- 0.00015 \pm 0.00008$. So, the protamine- modified COC has the same charged density as the protamine- modified PC. In conclusion, either using COC or PC substrate, we can achieve the same modified surfaces.

3.3.3- Adsorption of heparin on bare COC channels and on protamine modified COC channels:

Figure 3.3 shows insignificant changes in the streaming potential when heparin is adsorbed on bare COC channel, from -0.130 to -0.090 (V) for 800 seconds. Without heparin in the buffer solution, the streaming potential of protamine- modified COC surface was positive, from 0.041 to 0.031 (V) during 800 seconds. With heparin in phosphate buffer, the streaming potential gradually decreases, from 0.044 to $- 0.070$ (V) during 500 seconds. Since the adsorption of heparin on bare COC does not effectively change the streaming potentials, the reduction of signal is attributed to the interaction of heparin in the solution and adsorbed protamine. Because of this reason, protamine- modified COC channels can be chosen for heparin sensing. The same phenomena can be observed with protamine- modified PC channels (data is not shown). In a previous study,

we considered the two ways of measuring streaming potential, which are continuous monitoring, (taken with analyte in the solution), and measuring after analyte adsorption with analyte- free solution. It was found that using analyte- free solution was the better way for bovine serum albumin and streptavidin.⁵⁴The variation of signal in adsorption phase and desorption phase of heparin are shown in Figure 3.3. During the adsorption phase, with the same heparin concentration, the signal contributed from three different protamine modified channels appears similarly. During the desorption phase, the signals are different (arrow indicates injection moment of heparin free buffer solution for the desorption). To investigate how much different between using adsorption phase and desorption phase for heparin detection, three chips of protamine- modified COC were tested. Figure 3.5 shows the variation of signal of the adsorption phase of heparin at the same concentration on three protamine modified COC channels for 60 seconds, and Figure 3.4 shows the variation of signal of the desorption phase. The slopes of these curves were determined. For the adsorption phase, RSD = 4%, and the 95% confidence interval of the slopes is -0.00127 ± 0.00012 . For the desorption phase, RSD = 490%, and the 95% confidence interval is 0.00047 ± 0.00579 . Even though, the same concentration of heparin was used, the signal of heparin adsorption phase is more repeatable than that of the desorption phase. In conclusion, detection of heparin by continuous monitoring works better than measuring by free- analyte solution.

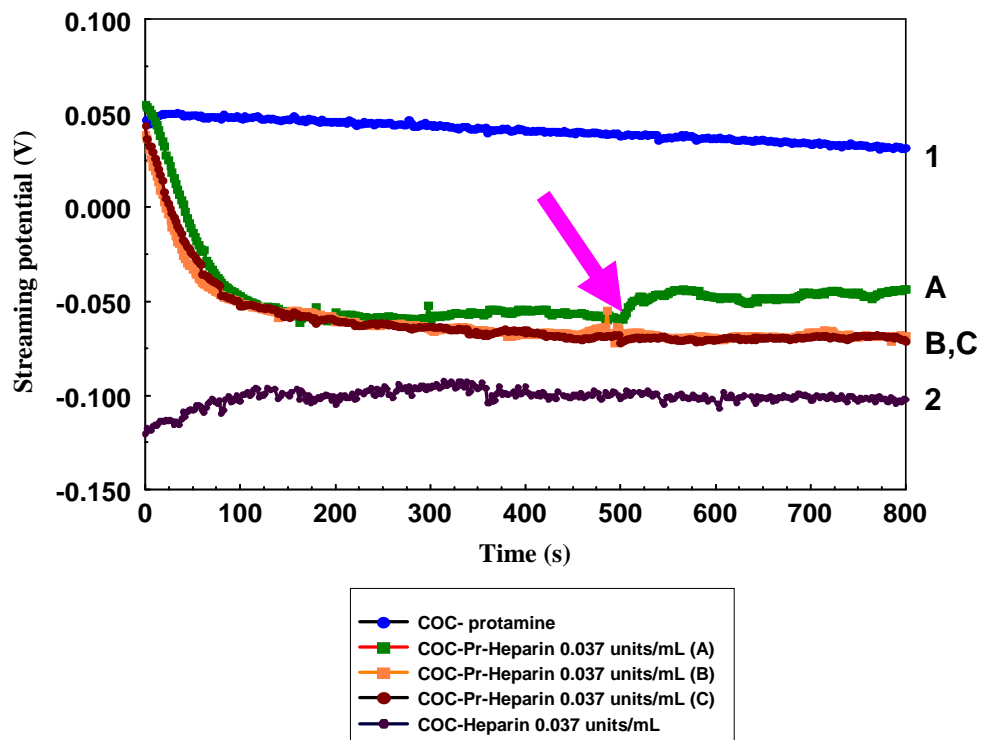

Figure 3.3: Variation of streaming potential of protamine- modified Cyclic Olefin Copolymer (COC) channel. A, B, and C were obtained by flushing heparin 0.018 units/mL in phosphate buffer through protamine modified COC channels for 500 seconds, then flushing heparin- free phosphate buffer solution to wash the heparin surface (arrow indicates washing moment). 1 was obtained by flushing phosphate buffer through protamine- modified COC channels. 2 was obtained by flushing heparin 0.018 units/mL in phosphate buffer through bare COC channels. All solutions were at pH 7.5 and conductivity $397 \pm 1 \mu\text{S/cm}$. Pulsed pressure was 60 cm Hg. Each reported data was the average of two.

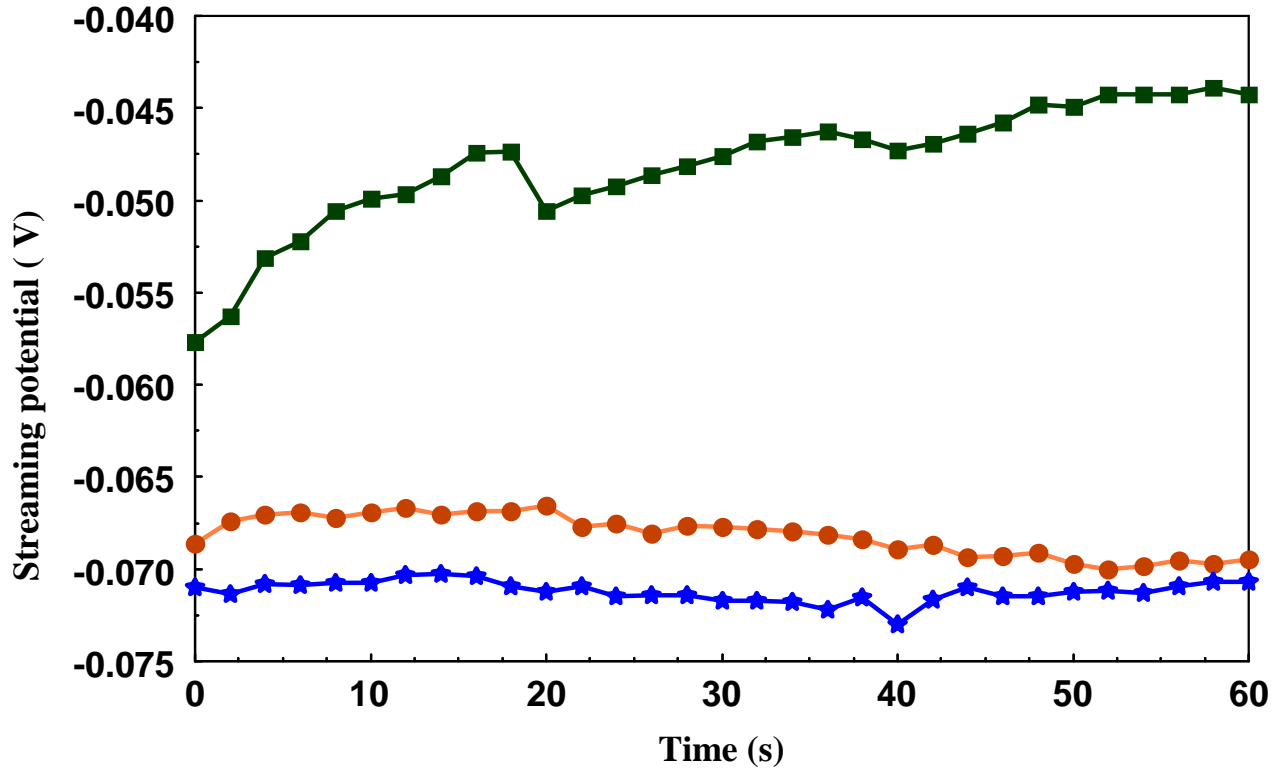

Figure 3.4: Variation of streaming potential obtained by desorption phase of adsorbed heparin at the same concentration on three different protamine- modified COC channels. Washing was done by heparin- free phosphate buffer, pH 7.5.

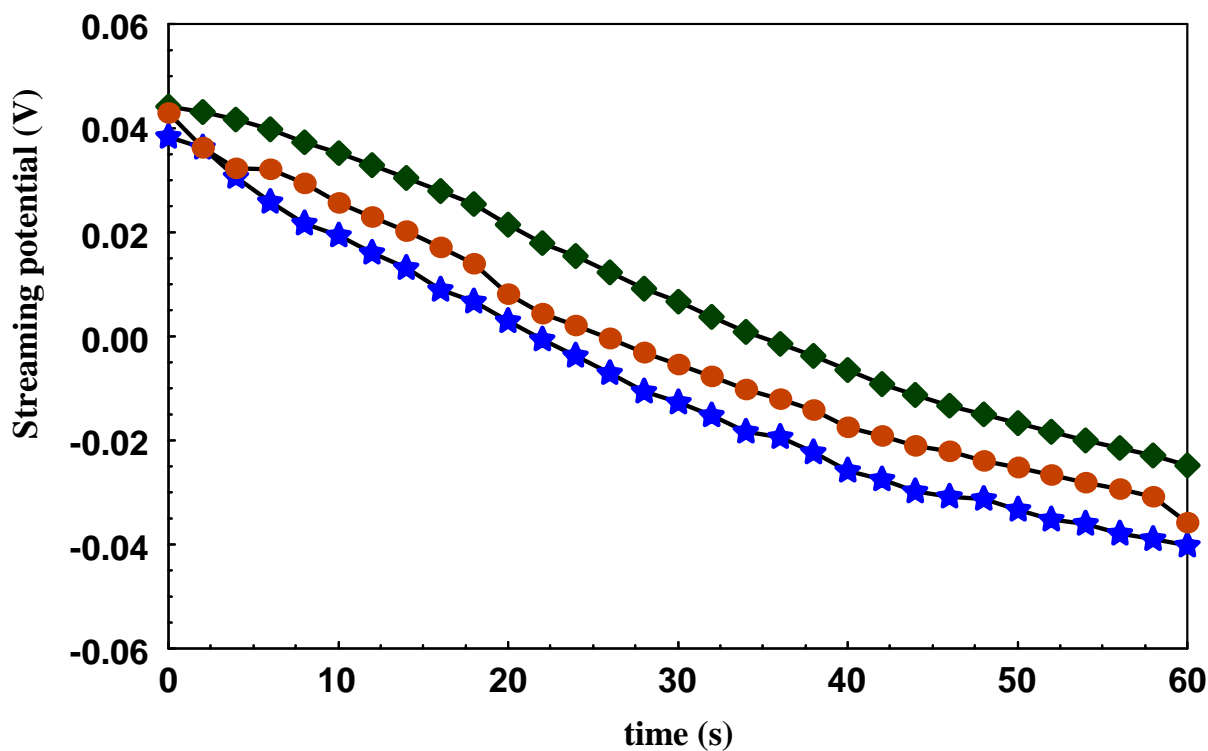

Figure 3.5: Variation of streaming potential obtained by heparin adsorption at the same concentration in phosphate buffer solution on three different protamine- modified COC channels.

3.3.4- Adsorption of heparin at different concentration on protamine- modified COC channels and on protamine- modified PC channels:

The announced data in Figure 3.6 and Figure 3.7 is the corrected streaming potential values, E_c , obtained by the reported streaming potential divided to the initial value at 0 second, described in experimental section, in order to bring all initial value to 1.00. According to Figure 3.6 and Figure 3.7, without heparin in solution, the corrected streaming potential of both kinds, protamine modified PC and protamine modified COC surfaces, were at maximum positive value, which is 1. With heparin in solution, negative charged heparin binds to the protamine, neutralizing positive charge on the EDL.⁴⁶ We previously showed that increasing heparin concentration steadily reduced the streaming potential.⁵⁴ It is also what we observe in this work. In cases of COC and PC, with the heparin concentration of 0.11 units/mL, the corrected streaming potentials vs. time curves show a plateau at E_c around -1 and almost overlap with the 0.074 units/mL curves. So, 0.11 units/mL is the lowest concentration that can saturate the surfaces of both protamine modified COC and PC channels. This is evidence that similar positive charge density of protamine layer on COC substrate and on PC substrate is produced.

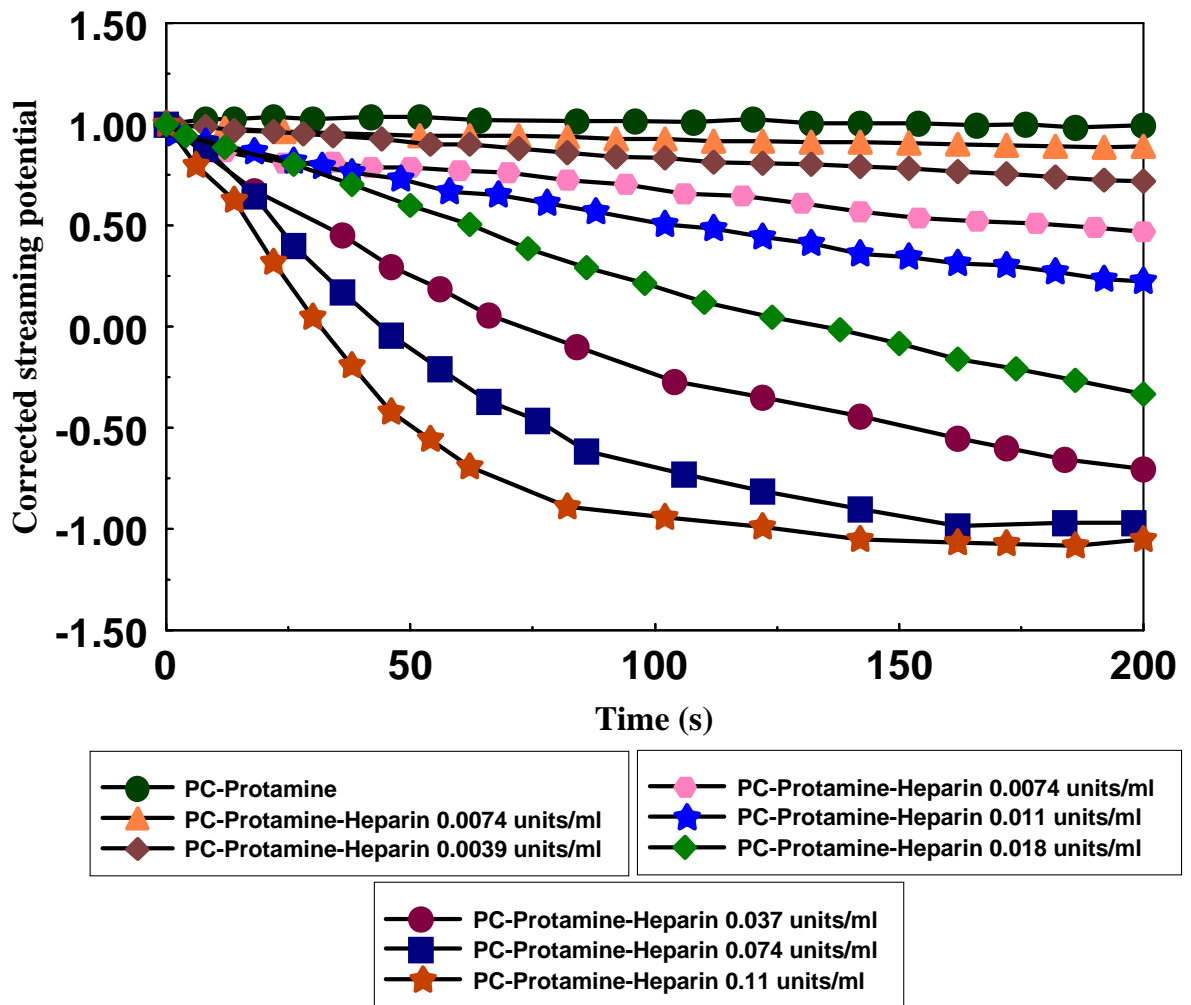

Figure 3.6: Variation of the corrected streaming potential (E_c) vs. time using polycarbonate channels modified with 0.10 mg/mL protamine. Results correspond to the streaming potential generated by flushing phosphate buffer (pH 7.5) without heparin, (PC- Protamine 1.0 mg/mL), and with different heparin concentrations, (PC- Protamine-Heparin), using a pulsed pressure at 60 cm Hg. The conductivity of all solutions was kept constant at $397 \pm 1 \mu\text{S/cm}$.

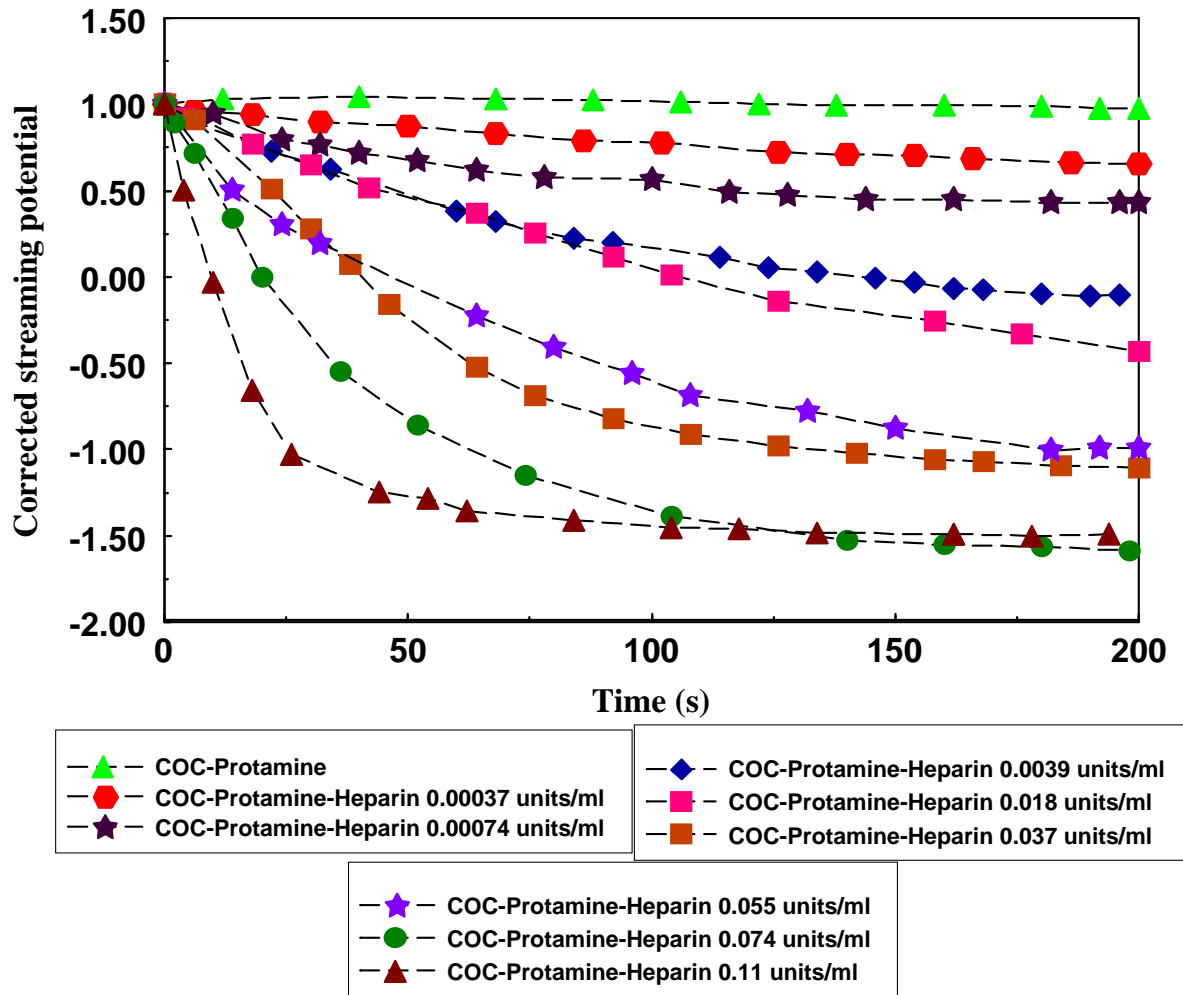

Figure 3.7: Variation of the corrected streaming potential (E_c) vs. time of Cyclic Olefin Copolymer channels modified with 0.10 mg/mL protamine. Results correspond to the streaming potential generated by flushing phosphate buffer (pH 7.5) without heparin (COC- Protamine) and with different heparin concentrations (COC- Protamine- Heparin) using a pulsed pressure at 60 cm Hg. The conductivity of all solutions was kept constant at $397 \pm 1 \mu\text{S/cm}$.

3.3.5- Calibration curves of different heparin concentrations:

In a previous study, we reported the linear relationship of initial adsorption rates of Lysozyme on COC microchannel surface and the bulk concentration of Lysozyme.⁵⁵ In this work, we use the same strategy to investigate the detection of heparin kinetically in order to compare with our previous method, which measured streaming the potential of adsorbed heparin by free heparin buffer, and can detect heparin in the range of 0.01 - 0.10 units/mL.⁵⁴ As we can see, in figure 3.6 and 3.7, the corrected streaming potential vs. time curves have linear regions in the first 60 seconds. Previously, in section 3.3.3, Figure 3.5, we observed the repeatability of the slopes (-0.00127 ± 0.00012) of three adsorption curves in the first 60 seconds with the same heparin concentration. So, these slopes were chosen as the principle for detection. Three protamine modified COC, and three protamine modified PC channels were used for each heparin concentration. Corrected streaming potential (E_c) vs. time curves were adjusted. The slopes, dE_c/dt , of these curves in the first 60 seconds were determined. Each reported point in Figure 3.8 and Figure 3.9 is the average of the three slopes. The standard deviation is represented by the error bars. It is found that there is a linear relationship of these slope values and the heparin concentrations, ranging from 0.00074 - 0.07400 units/mL for modified PC, and from 0.00074 - 0.05500 units/mL for modified COC microchannels. Figure 3.5 and Figure 3.6 are heparin calibration curves. The limit of detection for protamine modified COC channel is 0.00035 units/mL and is 0.00048 units/mL for protamine modified PC channels. This allows to detect heparin concentrations at lower values than our previous reported result,⁵⁴ and than those proposed a reported in previous studies (0.05 – 1.5 $\mu\text{g/mL}$, which corresponds to 0.008 - 0.25 units/mL) using ion channel sensor modified

by SAMs and electrochemical cyclic voltametry.⁴⁶ As we can see in Figure 3.8 and Figure 3.9, the slopes of the calibration curves are similar, which is -0.31 for PC modified channels and -0.34 for COC modified channels. The similar of these calibration curves provides more evidence to say that either adsorption of protamine on COC or PC surface, the result protamine surface is the same. So both COC and PC can be chosen to be a platform of heparin detection methods. Nevertheless, when comparing the two linear calibration curves, the range, which is 0.00074 - 0.05000 units/mL, of heparin concentrations detected by COC modified channels is shorter than the range by PC modified channels, which is 0.00074 - 0.07400 units/mL. Beside, the heparin calibration curve obtained by PC has better linear relationship with $R^2 = 0.99790$, compare to $R^2 = 0.979862$ obtained by COC.

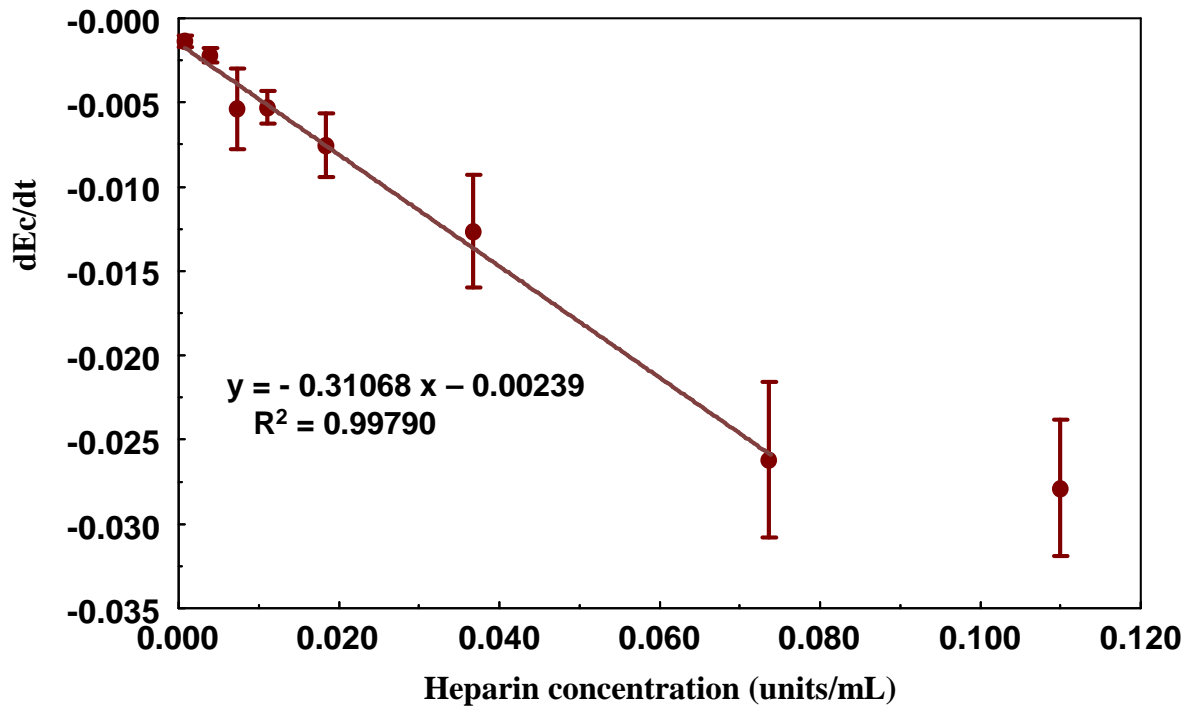

Figure 3.8: Calibration curve for heparin detected by protamine modified polycarbonate channels. dE_c/dt represents the slopes of the corrected streaming potential vs. time curves obtained during the first 60 seconds of heparin adsorption in phosphate buffer (pH 7.5) using a pulsed pressure of 60 cm Hg. The conductivity of all solutions was kept constant at $397 \pm 1 \mu\text{S/cm}$. Error bar represents the standard deviation.

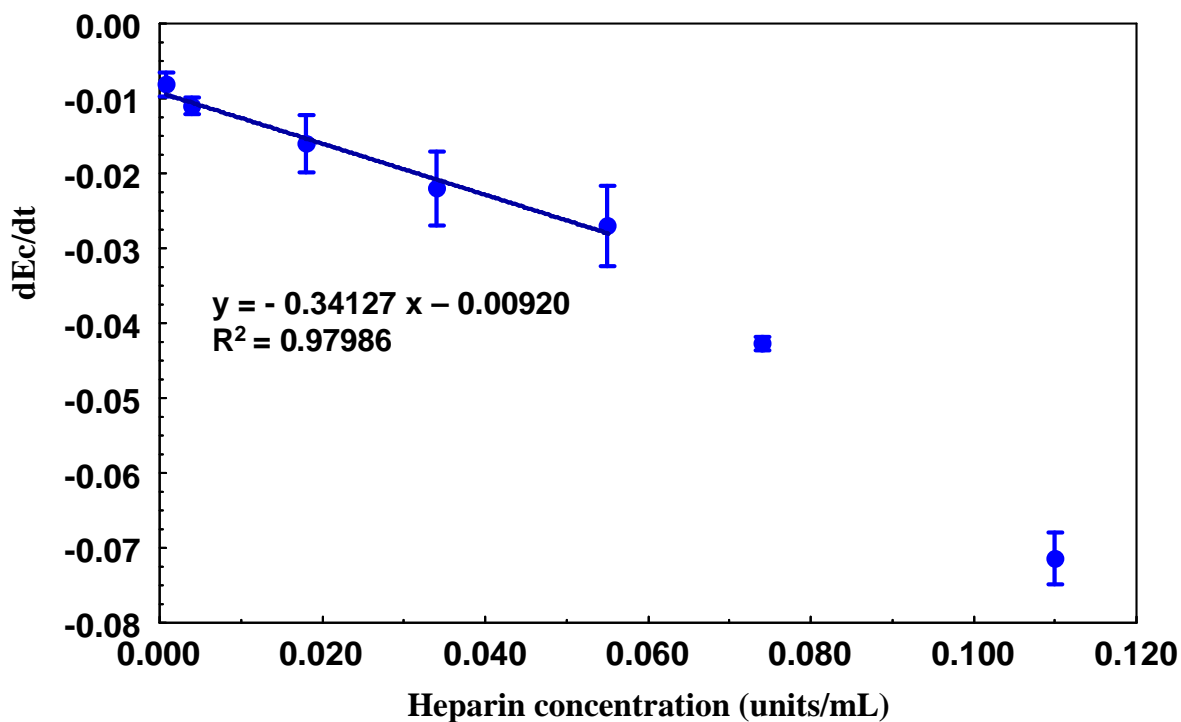

Figure 3.9: Calibration curve for heparin detected by protamine modified Cyclic Olefin Copolymer channels. dE_c/dt represents the slopes of the corrected streaming potential vs. time curves obtained during the first 60 seconds of heparin adsorption in phosphate buffer (pH 7.5) using a pulsed pressure of 60 cm Hg. The conductivity of all solutions was kept constant at $397 \pm 1 \mu S/cm$. Error bar represents the standard deviation.

3.4- Conclusion:

COC and PC microfluidic channels have been used for the detection of heparin. The detection is based on pulsed streaming potential measurements. The principle for detection is the linear relationship of initial adsorption rates with the bulk heparin concentration in the range of 0.00074 – 0.074 units/ mL. The response time is fast, which is 60 seconds. Linear calibration curves can be achieved by both kinds of the substrates, but the curve obtained by PC substrate has better linear relationship, and wider range for heparin detection. In addition, PC is cheaper and easier to find than COC. So, for this method of detection, PC is a better choice as a substrate.

Appendix

Proposal lab experiments for undergraduate and high school chemistry.

Adsorption studies by pulsed streaming potentials in microfluidic channels

Goals

- Fabricate microfluidic channels from polycarbonate.
- Modify polycarbonate channels by different charged species.
- Make different phosphate buffer solutions.
- Identify pH, temperature, and adjust the conductivity of a solution.
- Monitor the changes of streaming potential when changing charged surface, pH, or pressure.
- Calculate the Zeta potentials from the streaming potentials.

Discussion

The Zeta potential: In a colloid system of solid and liquid, at the interface of the particle and the surrounding liquid environment, an electric double layer is formed by the surface charge of the particle and counter ions in solution. The liquid layer surrounding the particle exists as two parts. The first one is the Stern layer, where the ions are kept strongly by the surface charge. The second part is the diffuse region, where the ions are less strongly bound to the surface. When the particle moves, the ions inside the Stern layer and the ions on the closest part of the diffuse layer of the particle surface move with the particle. The rest of the diffuse layer stays with the bulk liquid. The plane that

separates the moving and the sessile layer of ions part is called the plane of shear. The potential at this plane is called Zeta potential

The streaming potential: Similar to what happens in colloidal particles, inside a microchannel, at the interface of the channel wall surface and liquid, an electric double layer, (EDL), is generated by the surface charge of the wall and the counter ions in the solution. This EDL is about 1 nm thick, which changes according to the ionic strength of the solution. When hydrostatic pressure is applied to the solution in the channel, liquid is forced to move forward inside the channel. This movement causes a displacement of the mobile counter ions at the EDL, which in turn produces an excess of counter ions at the downstream end of the channel while the upstream end lacks of counter ions. The result is a streaming potential, ΔE that is generated between the two ends of the channel.

The Smoluchowsky equation (Eq. 1):

$$\zeta = \eta \lambda / \varepsilon \times \Delta E / P \quad (\text{Eq. 1})$$

In equation 1, ζ is the Zeta potential in volts, η is the solution viscosity in Pascals- second (Pa-s), λ is the conductivity of buffer solution in Siemens per meter (S/m), ε is the dielectric permittivity, ΔE is streaming potential (V), and P is pressure (Pa). If the applied pressure, dielectric permittivity, viscosity, and conductivity of the solution are kept constant, streaming potential will depend mostly on the Zeta potential. Zeta potential is heavily dependent on pH because protonation can change the charge of some chemical functionality. A plot of Zeta potential versus pH could be positive or negative depending on how the surface charge changes with the pH.

In equation 1, streaming potential is proportional to the applied pressure, and there is a linear relationship between the streaming potentials and the pressure.

The isoelectric point: the value of pH at which Zeta potential is equal to zero

Microfluidics studies the changing behaviors of fluids within small volumes, (nl, pl, fl), or small sizes, (channel size is about 100 nanometers to several hundred micrometers).

Polycarbonate, LEXAN, has the melting temperature at 267 °C. At around 150- 170 °C, under pressure, a metal wire can imprint its shape on a polycarbonate surface. So a microchannel with a desired size can be made by imprinting a metal wire on a polycarbonate surface.

Lab information

Time: for part 1: 2- 2½ hr

for part 2: 2- 3 h

Experiment Procedures

Part 1

A. Fabrication of polycarbonate,PC, microchannels:

Materials: Polycarbonate sheet 0.062” thick (2” x 0.7”), stainless steel wire 0.005

IN diameter, micro slides of glass (3” - 1” plain), paper clips.

A1. Take 6 PC pieces and 12 glass slides. Remove dust off the PC pieces and glass slides by air flow.

A2. Cut 3 stainless steel wires (1.5” long).

A3. Place one stainless steel wire at the center of one PC piece, piece A, sandwich it between two glass slides and secure by 4 paper clips, (Figure 1, and Figure 2).

Make three of this sandwich.

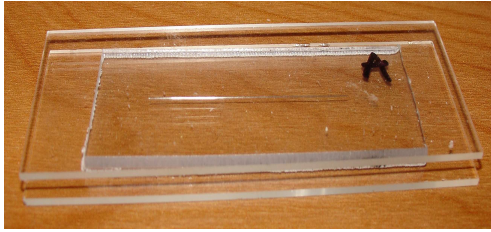

Figure 1



Figure 2

A4. Make three other sandwiches by the same process but without the stainless steel wire, piece B.

A5. Place all 6 of the assembly in the oven at 165 °C for 20 minutes.

A6. Take the assembly out and allow them to cool down. Then remove the clips, the glasses, and the wires.

A7. Place A on the top of B, using a marker place two dots B, the distance of the two dots is equal to the channel length on A, and then thrill two holes at the position of the marked dots. Do the same for other two PC pieces. (Figure 3 and Figure 4

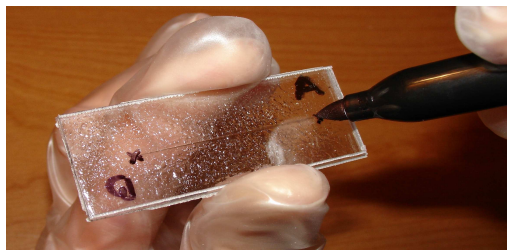

Figure 3



Figure 4

A8. Clean the 6 PC pieces by ethanol, dry by air. Then, place B on the top of A (make sure the channel is inside) so that the holes line up with the ends of the channel. Sandwich them between two glass slides and secure by 6 paper clips. Finish all three assemblies by the same process.(Figure 5)



Figure 5

A9. Place the three sandwiches in the oven at 150 °C for 15 minutes. Then, take them out and allow them to cool down. After removing the clips and the glass slides, you will have three finish microchips. (Figure 6)



Figure 6

B- Modification the chips:

Materials: Two polycarbonate chips, 1mL syringe, flexible plastic tubing which can tightly cover the end of the syringe,

Poly(allylamine hydrochloride), PAH, 5 mM solution.

Poly(styrene sulfonate) sodium salt, PSS, 0.2 mM solution.

Cup of DI water.

B1. Cut a ½” long piece of the flexible plastic tubing, attach the tubing on the end of the syringe.

B2. Use the syringe to pick up a small amount of PAH solution. Place the end of the syringe on one hole of a PC channel and pump the solution through the channel until you see the liquid appear at the other end of the channel. Leave the solution inside the channel about 5 minutes for the adsorption to occur.

B3. Clean the syringe by DI water. After the solution has seated in the channel for 5 minutes, use the syringe to pick up water and pump the water through the channel about five times to wash out the excess solution. Wipe the chip.

B4. Use the same process to modify the other channel with PSS solution.

Part 2

A. Making buffer solutions

Materials: Nine 10.0 mL test tubes, test tube rack, pipet.

Set of solutions: A (10.0 mM H_3PO_4), B (20.0 mM NaH_2PO_4), C (10.0 mM Na_2HPO_4), D (10.0 mM Na_2HPO_4 and 10.0 mM NaOH).

DI water.

A1. Label the test tubes from 1 to 9

A2. To make buffer solution 1, take 590 μL A by a pipet, and release the solution in test tube number 1, add DI water to have 10 mL solution.

A3. Use the same process of making buffer solution 1 to make each 10 mL buffer solution 2- 9, but use following amount of A, B, C, and D:

- Buffer solution 2: 120 μL A + 100 μL B
- Buffer solution 3: 10 μL A + 30 μL B

- Buffer solution 4: 1 160 μ L B + 120 μ L C
- Buffer solution 5: 380 μ L B + 752 μ L C
- Buffer solution 6: 60 μ L B + 1 010 μ L C
- Buffer solution 7: 950 μ L C + 50 μ L D
- Buffer solution 8: 190 μ L C + 140 μ L D
- Buffer solution 9: 510 μ L D

B. Measuring the conductivity, temperature and pH of the buffer solutions:

Materials: Nine test tubes, test tube rack, thermometer, pH meter, and conductivity apparatus.

Dropper bottle of NaCl 50 nM solution.

Use the conductivity apparatus to measure the conductivity of the nine buffer solutions. Drop NaCl 50 nM solution in the solutions which have lower conductivity so that all of the solutions have almost similar conductivity, record. Place 3- 4 mL of each buffer solution in a test tube, label the sample. Use the thermometer to measure the temperature of each sample, record. Use the pH meter to identify the pH of each sample, record.

C. Measuring streaming potential of PC- PAH modified channel, and PC-PSS modified channel

Materials: Streaming potential machine, PC modified microchips made in part 1, phosphate buffer solutions.

C1. Set up the machine

Place the PDMS washer on one hole of the channel (make sure that one end of the Pt electrode is inside the hole), place the Straight Barbed on the top of the washer, and then

tighten well the screws, connect the Microchip Holder as in the below picture, (connect the Black Alligator Clamp to the other end of the Pt electrode on the PDMS washer, connect one end of the other electrode to the Red Alligator Clamp, place the free end of the electrode in the free hole of the channel.)

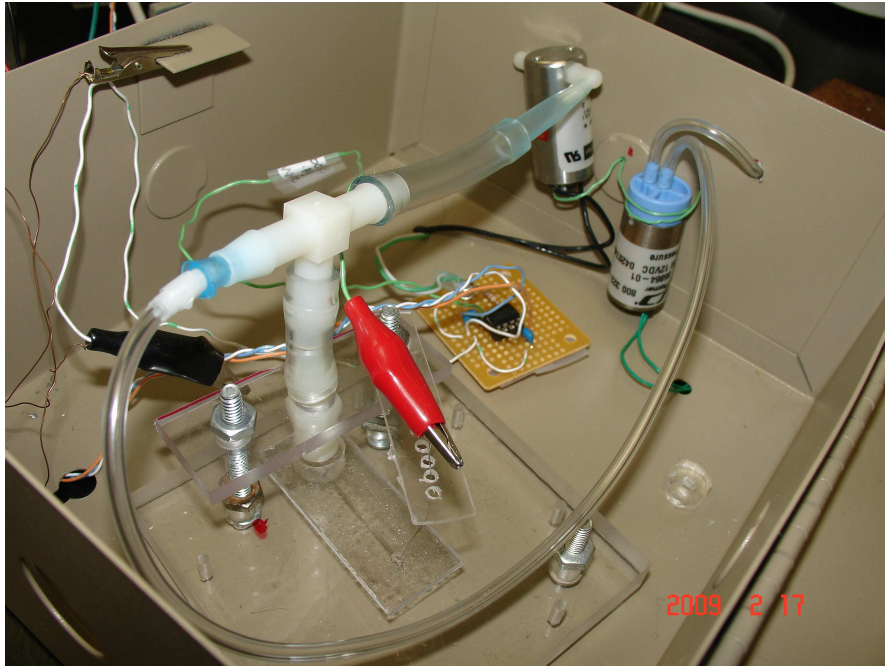

C2. Turn on the power supply

Use a short wire (as the Red wire in the picture beside) to connect the third and the fourth holes of P1 (look for P1. Look at the opposite side of P1-the bottom row, count from left to right for the third and the fourth holes.). If the red light on P5 is on, the power supply is on.

C3. Turn on the vacuum; adjust the pulsed pressure at 60 cm Hg

C4. Turn on the computer.

Use buffer solution 1, place a drop of the solution on the free hole of the channel. Be sure that the drop of liquid covers well the hole and without air bubble. Close the box. On the computer, go to SP Auto, click the RUN button (the arrow on the upper left corner), name the file and save it, repeat the process in order to have stable signal, which means that the average values of streaming potential between these measurements are not very different, clean extra liquid remaining on the chip, and process the measurement with another pH.

For checking the result, go to SP calc. The average of the streaming potentials, Stdev, and RSD % will be showed.

C5. Collect data

Go to SP calc, go to “write to a file” click the red button, NO will be replaced by YES, click the folder button on the upper right corner. Pick up randomly one file. Click “OPEN”. Add .csv to the end of the file name, click Run button (the arrow on the left), choose one result for each pH (may be the last result), data now is collected in this file.

D. Modifying the PC chip by BSA and measuring the streaming potentials

Materials: The streaming potential machine, PC blank chip made in part 1

Dropper bottle of BSA 43 mg/mL solution

Set up the chip in the microchip holder as described in C, place a drop of BSA 43mg/ml solution on the free hole of the channel, go to Flushing control, Set T open 60 seconds, set flushing ON. Click Run button, check the drop of liquid and fill it if necessary while running the flushing control, clean extra liquid , then measure the streaming potential with different pH using the same process as in previous sections.

Calculation

Calculate the Zeta potentials from the streaming potentials using the the Smoluchowsky equation.

Graph

- Graph the streaming potentials vs. pH
- Graph the Zeta potentials vs. pH

References

1. Gusev, I.; Horvath, C., *Journal of Chromatography A* **2002**, 948, 203- 223.
2. Fa, K.; Paruchiri, V. K.; Brown, S. C.; Moudgil, B. M.; Miller, J. D., *Physical Chemistry Chemical Physics* **2005**, 7, 678- 684.
3. Kirby, B. J., *Cambridge University Press* **2010**.
4. Yaroshchuk, A. E.; Boiko, Y. P.; Makovetskiy, A. L., *Langmuir* **2002**, 18, 5154- 5162.
5. Lorne, B.; Perrier, F.; Avouac, J. P., *Journal of Geophysical Research* **1999**, 10, 17857- 17877.
6. Hunter, J. R., *Zeta potential in colloid science and applications*. **1981**.
7. Arulanandam, S.; Li, D., *Journal of Colloid and interface science* **2000**, 2225, 421- 428.
8. Anderson, J. L.; Idol, W. K., *Chemical Engineering Communication* **1985**, 38, 93- 106.
9. Moore, W. J., *Physical Chemistry*, 4th Edition. **1972**.
10. Chang, H. C.; Yeo, L., Y., *Electrokinetically Driven Microfluidics and Nanofluidics*. **2009**.
11. Moasier, B. D.; Molho, J. I.; Santiago, J. G., *Experiments in fluids* **2002**, 33, 545- 555.
12. Paull, P. H.; Gaguilo, M. G.; Rakestraw, D. J., *Analytical Chemistry* **1998**, 70, 2459- 2467.
13. Ross, D.; Locascio, L. E., *Analytical Chemistry* **2003**, 1, 2509- 2515.

14. Ross, D.; Locascio, L. E., *Analytical Chemistry* **2003**, 1, 1218- 1220.
15. Kirby, B. J.; Hasselbrink, E. F., *Electrophoresis* **2004**, 25, 187- 202.
16. Das, S.; Chakraborty, S., *Langmuir* **2009**, 25, (17), 9863- 9872.
17. Lac, E.; Sherwood, J., D., *The Journal of Fluid Mechanics* **2009**, 640, 55- 77.
18. Scales, P. J.; Grieser, F.; Healy, T. W., *Langmuir* **1992**, 8, 965- 974.
19. Park, H. M.; Lim, J. Y., *Journal of Colloid and interface science* **2009**, 336, 834- 841.
20. Adamczyk, Z.; Zembala, M.; Warszynski, P.; Jachimska, B., *Langmuir* **2004**, 20, 24.
21. Van Wagenen, R. A.; Andrede, J. D., *Journal of Colloid and interface science* **1980**, 76, 305.
22. Luna- Vera, F., Development of immunosensors based on streaming potential transductor. *Unpublished Doctoral Dissertation Virginia Common Weath University* **2011**.
23. Huang, T. L., *Chromatographya* **1993**, 35, 395- 398.
24. Reid, R. H. P., *Journal of Chromatography A* **1994**, 669, 155- 161.
25. Lambert, W., J.; Middleton, D., L., *Analytical Chemistry* **1990**, 62, 1585- 1587.
26. ChemicalBook. *Google.com*.
27. Silva, C. D.; Carapuca, H., M., *Electrochimica Acta* **2006**, 52, 1182- 1190.
28. Ruths, J.; Essler, F.; Decher, G.; Riegler, H., *Langmuir* **2000**, 16, 8871- 8878.
29. Primorac, E.; Dapic, I.; Strbe, N.; Kovacevic, D., *Colloid and surfaces B: Biointerfaces* **2010**, 76, 305- 310.
30. Burke, S. E.; Barrett, C. J., *Langmuir* **2003**, 19, 3297- 3303.

31. Hoshi, T.; Saiki, H.; Kuwazawa, S.; Tsuchiya, C.; Chen, Q.; Anzai, J. I., *Analitacal Chemistry* **2001**, 73, 5310- 5315.
32. Stanton, B. W.; Harris, J. J.; Miller, M. D.; Bruening, M., L., *Langmuir* **2003**, 19, 7038- 7042.
33. Lvove, Y.; Ariga, K.; Onda, M.; Ichinose, I.; Kunitake, T., *Colloids and surfaces a physicochemical and enginerring aspects* **1999**, 146, 337- 346.
34. Ge, S.; Kojio, K.; Takhahara, A.; Kajiyama, T., *Journal of Biomaterials Science Polymer Ed* **1998**, 9, (2), 131- 50.
35. Ang, W., S.; Elimelech, M., *Journal of Membrane Science* **2007**, 296, 83- 92.
36. Jacobson, S., C.; Guiochon, G., *Analitacal Chemistry* **1992**, 64, 1496- 1498.
37. Peng, Z., G.; Hidajat, K.; Uddin, M. S., *Journal of Colloid and interface science* **2004**, 271, (2), 277-283.
38. Rezwan, K.; Meier, L., P.; Gauckler, L., J., *Langmuir* **2005**, 21, (8), 3493- 3497.
39. Freeman, N., J.; Deel, L., L.; Swann, M., J.; Cross, G. H.; Reeves, A.; Brand, S.; Lu, J., R., *Journal of Physics: Condensed Matter* 16, 2493.
40. Cox, M.; Nelson, D., Lehninger, principles of Biochemistry. **2004**, 1100.
41. Casu, B., Heparin and Related Polysaccharides Structure and Activities. *The New york Academy of sciences* **1989**, 556.
42. Chmidt, F.; Faul, C.; Dichgan, J.; Weller, M., *Journal of Neurology* **2002**, 249, 1409-1412.
43. Kock, H.; Hanschin, A., *Clinical and Applied Thrombosis/ Hemostasis* **2002**, 8, 251- 255.

44. Rodie, V.; Thomson, A.; Steward, F.; Quinn, A.; Walker, I.; Greer, I., *British Journal of Obstetrics and Gynaecology* **2002**, 109, 1020- 1024.
45. Debois, W., J.; Liu, J. L.; Lee, L. Y.; Giradi, L. N.; Mack, C.; Totolani, A.; Krieger, K. H.; Isom, O. W., *Perfusion* **2003**, 18, 47-53.
46. Gadzedpo, V., P., Y.; Buhlmann, P.; Xiao, K., P.; Aoki, H.; Umzawa, Y., *Analytical Chimica Acta* **2000**, 411, 163- 173.
47. Hirsch, J.; Wendt, T.; Kuhly, P.; Schaffartzik, W., *Anaesthesia* **2001**, 56, 760-763.
48. Cheng, T. J.; Lin, T., M.; Chang, H., C., *Analytica Chimica Acta* **2002**, 462, 261- 273.
49. Bull, S. B.; Huse, W., M.; Brauer, F. S.; Kopman, R., A., *The journal of Throacic and Cardiovascular surgery* **1975**, 69, 685.
50. Jaques, L. B., *Pharmacological Reviews* **1980**, 31, 99.
51. Teoh, K., H., T.; Young, E.; Blackall, M. H.; Roberts, R. S.; Hirsh, J., *The Journal of Thoracic and Cardiovascular Surgery* **2009**, 128, 211.
52. Oite, T.; Shimizu, F.; Batsford, S. R.; Vogt, A., *Clinical and Experimental immunology* **1986**, 64, 318- 322.
53. Linhardt, R., *Chemical Industry* **1991**, 21, 45.
54. Pu, Q.; Elazazy, M., S.; Alvarez, J., C., *Analytical Chemistry* **2008**, 80.
55. Luna- Vera, F.; Alvarez, J., C., *Biosensors and Bioelectronics* **2010**, 25, 1539- 1543.
56. Pu, Q.; Alvarez, J., C., **2006**.
57. Gaus, K.; Hall, E., A.,H., *Journal of Colloid and interface science* **1997**, 194, 364.

58. Kerkhof, V., J., C.; Berveld, P.; Ischasoort, R., B.M., *Biosensors and Bioelectronics* **1993**, 8, 463.
59. Eckert, G.; Gutmann, F., *Electroanalytical Chemistry and Interfacial Electrochemistry* **1975**, 62, 267- 272.